

TTL to RS232 Adapter User Guide

**Revision C April 16, 2007
Document Part Number GC-800-313**

Copyright and Trademark

Copyright © 2006, Grid Connect, Inc. All rights reserved.

No part of this manual may be reproduced or transmitted in any form for any purpose other than the purchaser's personal use, without the express written permission of Grid Connect, Inc. Grid Connect, Inc. has made every effort to provide complete details about the product in this manual, but makes no warranty of any kind with regard to this material, including, but not limited to, the implied warranties of merchantability or fitness for a particular purpose. In no event shall Grid Connect, Inc. be liable for any incidental, special, indirect, or consequential damages whatsoever included but not limited to lost profits arising out of errors or omissions in this manual or the information contained herein.

Grid Connect, Inc. products are not designed, intended, authorized or warranted for use as components in systems intended for surgical implant into the body, or in other applications intended to support or sustain life, or in any other application in which the failure of a Grid Connect, Inc. product could create a situation where personal injury, death, or severe property or environmental damage may occur. Grid Connect, Inc. reserves the right to discontinue or make changes to its products at any time without notice.

Grid Connect and the Grid Connect logo, and combinations thereof are registered trademarks of Grid Connect, Inc. DSTni is a trademark of Lantronix, Inc. All other product names, company names, logos or other designations mentioned herein are trademarks of their respective owners.

XPort is a trademark of Lantronix. Ethernet is a trademark of XEROX Corporation. UNIX is a registered trademark of The Open Group. Windows 95, Windows 98, Windows 2000, Windows NT, and Windows XP are trademarks of Microsoft Corp. Netscape is a trademark of Netscape Communications Corporation.

Grid Connect

1841 Centre Point Circle, Suite 143
Naperville, IL 60563, USA
Phone: 630.245.1445

Technical Support

Phone: 630.245.1445
Fax: 630.245.1717
On-line: www.gridconnect.com

Disclaimer and Revisions

The information in this guide may change without notice. The manufacturer assumes no responsibility for any errors that may appear in this guide.

Date	Rev.	Author	Comments
01/09/06	A	GR	Preliminary Release
02/23/07	B	GR	Change C6, C7 to 35V. Input range now 5-24VDC.
04/16/07	C	GR	Remove note. Add cable drawing.

Warranty

Grid Connect warrants each product to be free from defects in material and workmanship for a period of **ONE YEAR** after the date of shipment. During this period, if a customer is unable to resolve a product problem with Grid Connect Technical Support, a Return Material Authorization (RMA) will be issued. Following receipt of a RMA number, the customer shall return the product to Grid Connect, freight prepaid. Upon verification of warranty, Grid Connect will -- at its option -- repair or replace the product and return it to the customer freight prepaid. If the product is not under warranty, the customer may have Grid Connect repair the unit on a fee basis or return it. No services are handled at the customer's site under this warranty. This warranty is voided if the customer uses the product in an unauthorized or improper way, or in an environment for which it was not designed.

Grid Connect warrants the media containing software and technical information to be free from defects and warrants that the software will operate substantially for a period of 60 DAYS after the date of shipment.

In no event will Grid Connect be responsible to the user in contract, in tort (including negligence), strict liability or otherwise for any special, indirect, incidental or consequential damage or loss of equipment, plant or power system, cost of capital, loss of profits or revenues, cost of replacement power, additional expenses in the use of existing software, hardware, equipment or facilities, or claims against the user by its employees or customers resulting from the use of the information, recommendations, descriptions and safety notations supplied by Grid Connect. Grid Connect liability is limited (at its election) to:

- 1) refund of buyer's purchase price for such affected products (without interest)
- 2) repair or replacement of such products, provided that the buyer follows the above procedures.

There are no understandings, agreements, representations or warranties, expressed or implied, including warranties of merchantability or fitness for a particular purpose, other than those specifically set out above or by any existing contract between the parties. The contents of this document shall not become part of or modify any prior or existing agreement, commitment or relationship.

1. Introduction

The TTL-RS232 Adapter is used to connect TTL level signals to an RS-232 interface. The TTL side is a 9-pin female connector and the RS-232 side is a 9-pin male connector. The unit can be powered through one of the connector pins or through the side mounted power jack (optional).

The TTL side has a voltage suppression network designed to protect against ESD and EFT.

The unit can be powered by supplying **5-24VDC** on pin 5 of the TTL connector.

WARNING: The power is passed through to pin 4 of the RS232 connector. The pass through option can be disabled by removing R2.

This unit can be powered by a **5-24VDC** power supply through an optional side mounted power jack.

2. Connections

TTL Signal Pin	Signal Name	RS232 Signal Pin
1 (Input)	TXD	3 (Output)
2 (Output)	RXD	2 (Input)
3 (Input)	RTS	7 (Output)
4	Ground	5
5	PWR	4 (See Note)
6 (Output)	CD	1 (Input)
7, 8, 9	No Connection	
		6, 8, 9

WARNING: Power from the external power supply is connected to pin 4 of the RS232 connector by an internal jumper R2. Remove R2 if you do not want power on RS232 connector pin 4.

3. Schematic

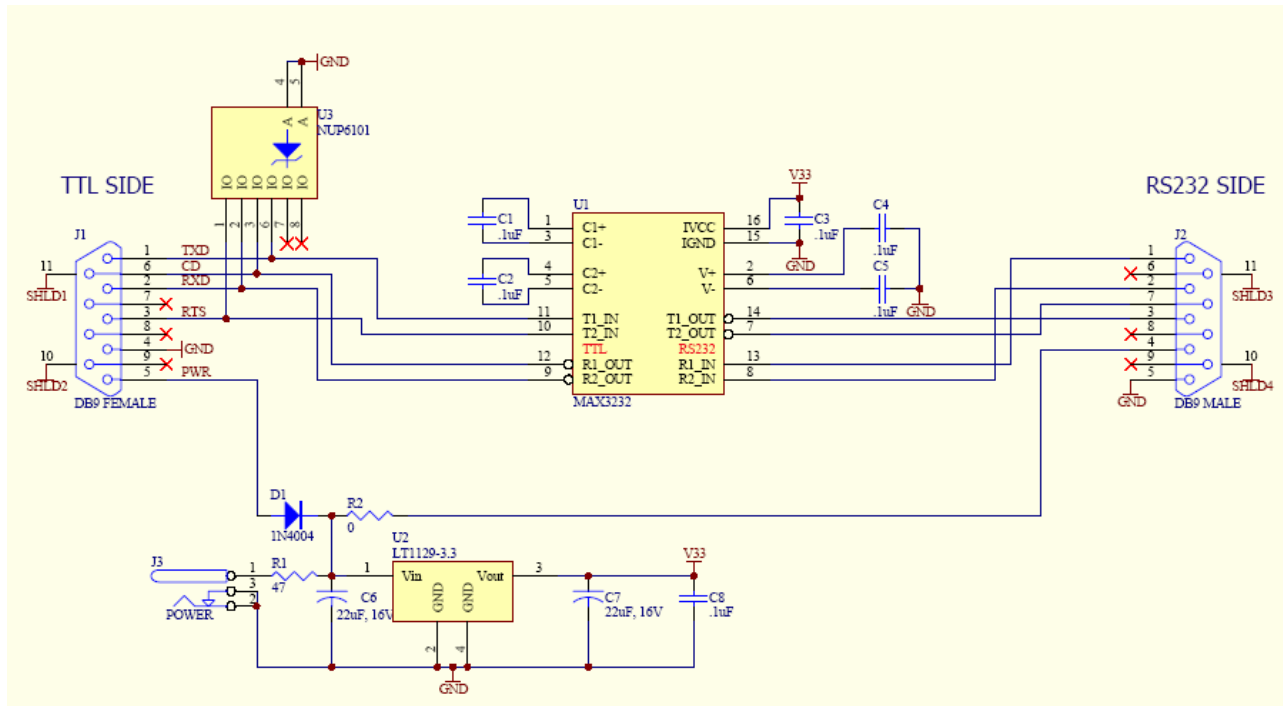

Note: C6 and C7 are 35VDC.

Grid Connect has a TTL to Ethernet product that has a TTL interface. The TTL-RS232 Adapter can be connected to the TTL-Ethernet Adapter so that an RS232 source can be used to setup and configure the TTL-ETH Adapter. The following cable diagram shows how to make a cable to connect a TTL-RS232 Adapter to a TTL-Ethernet Adapter.

Cable between TTL-232 and TTL-ETH

	DB9 Male		DB9 Female	
TO Female DB-9 on TTL-232 Adapter	TXD -1	—————	TXD -4	TO Male DB-9 on TTL-ETH Adapter
	RXD-2	—————	RXD-5	
	RTS-3	—————	RTS-9	
	GND-4	—————	GND-2	
	DCD-6	—————	DCD-3	

4. Technical Support

If you are experiencing a problem that is not described in this manual, please contact Grid Connect at (630) 245-1445.

Our phone lines are open from 8:00AM - 4:30 PM Central Time Monday through Friday excluding holidays.