

PCAN-USB Adaptor



Hardware manual

Version 1.3

Revision April 2003

Those products which are named in the manual, which at the same time have registered trademarks may not always be marked as such. The lack of the ® mark does not consequently mean that the product is freeware. Just as little can be placed on the basis of pending patents or protection of designs. It is expressly acknowledged, that the company PEAK-System Technik GmbH accepts no responsibilities for either guaranties, legal responsibilities or any liability for any consequential damage, which may arise from the use or contents of these hand-books. The rights are reserved to alter without prior permission, information contained in the hand-book. The company PEAK-System Technik GmbH accepts no liabilities whatsoever.

Furthermore it is expressly acknowledged, that PEAK-System Technik GmbH accepts no responsibilities either for guaranties or legal responsibilities or any liability for any consequent damage, which may arise from any misuse of the hardware. The rights are reserved to alter without prior permission, the Layout or Design of the hardware. PEAK-System Technik GmbH accepts no liabilities whatsoever.

© Copyright 2003 PEAK-System Technik GmbH - All rights reserved.

No parts of these books may be reproduced, processed, duplicated, transmitted or stored under any retrieval system, in any form without the written consent of the company PEAK-System Technik GmbH

PEAK-System Technik GmbH
Otto-Roehm-Str. 69
D-64293 Darmstadt / Germany

Phone: +49 (0)6151-8173-20
Fax: +49 (0)6151-8173-29
URL: www.peak-system.com
EMail: info@peak-system.com

Contents

1. INSTALLATION.....	4
2. THE PROGRAMM PCANVIEW USB.....	7
3. PCAN-USB LIGHT DRIVERS.....	8
4. CONNECTION TO THE CAN-BUS.....	9
5. SUPPLY VOLTAGE THROUGH THE SUB-D PLUG.....	10
6. SYSTEM REQUIREMENTS	11

1. Installation

The PCAN-USB adaptor is distributed with drivers for Windows 98/ME and Windows 2000/XP.

Installing the PCAN-USB adaptor (Example for Windows2000)

For installing the PCAN-USB adaptor follow the instructions below:

1. Start your computer.
2. Connect the PCAN-USB adaptor with your computer.

Then the hardware wizard becomes visible, which guides you through the installation:



Fig. 1: The PCAN-USB Adaptor was found

3. Choose „Search for the best driver for your device (Recommended)“ and press 'Next'.



Fig. 2: Searching for a driver



Fig. 3: Search for the best driver

4. Choose „floppy disk drive“ and insert the PCAN-USB disk to your floppy disk drive.



Fig. 4: Dialog after successful driver installation

Press **Next** for continue the installation.

5. The installation of the PCAN-USB drivers has finished now. Now install the PCAN-View for the PCAN-USB adaptor by starting PCAN-USB.EXE:



Fig. 5: Screen after driver installation

Please pay attention on the following informations for a safety use of the PCAN-USB adaptor in Windows2000:

- If the PCAN-USB adaptor is connected to your computer, you will see the „remove hardware“-item in your taskbar 
- For removing the PCAN-USB adaptor you have to klick on this item and deaktivate the hardware.
- If you succesfully deaktivated the PCAN-USB adaptor, the red LED on the PCAN-USB adaptor turned off. Now, you can remove the PCAN-USB adaptor from your USB interface.

If you use Windows98 you have to pay attention on the following things to remove the hardware:

- For removing the PCAN-USB adaptor you have to pay attention that the LED on the PCAN-USB adaptor doesn't flash. A flashing LED shows you that there is still data transfer between the USB-modul and the drivers. (for example if PCANView USB is aktivated).

ATTENTION:

If you disconnect the PCAN-USB adaptor while a PCAN-software is running the system can be hang up.

2. The programm PCANView USB

The CAN-Bus monitor PCANView is a easy to use programm for monitoring CAN-Bus systems. After starting the programm you can set the filter and the baudrate. Further informations about the handling of PCANView USB you can find in the online-help.

If you want to work with 29-bit IDs set the message-filter to „Extended“,

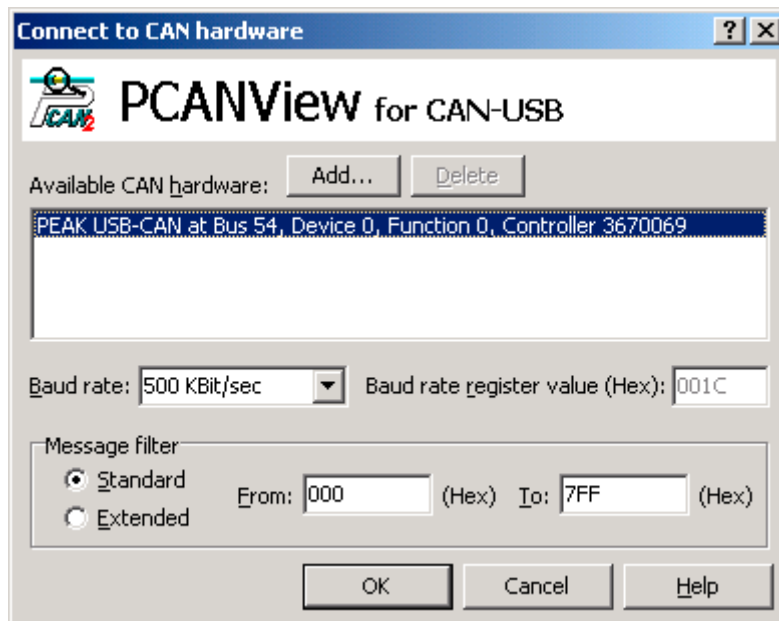

Fig. 6: Selection of the CAN-specific parameters

Select the desired baudrate and press „Enter“ or „OK“.

Main-window:

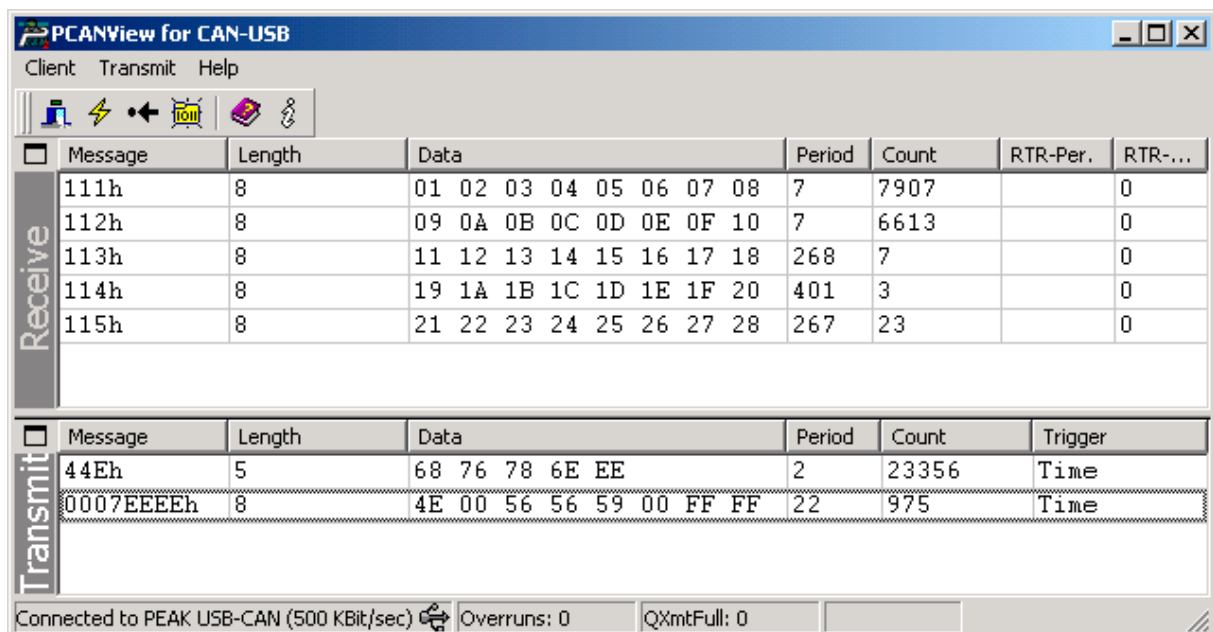

Fig. 7: Screen of the program PCANView USB

If you need help after the program starts, please press **F1** for the online-help.

3. PCAN-USB Light Drivers

All files in the PCAN-Light directory are only for developers. You are allowed to use this software ONLY if you use original PEAK-System Technik hardware.

The device drivers, the interface DLL as well as all others files needed for binding are property of PEAK-System Technik GmbH and you are only allowed to use it with a original PEAK-System Technik hardware. Every PEAK-System Technik hardware have ONE licence for the software. You are not allowed to use parts of these software with non PEAK-System Technik hardware !

PEAK-System Technik takes no liability and offers no support for the PCAN-Light drivers and the interface files. If other companys developpe software with these tools and you have problem with these software, please contact first the software developer of these companys.

In the directory PCAN-Light you find the PASCAL units, VB files and c/c++ header files to implement the interface to your favorite language.

Please see `pcan_usb.hlp` file which is include in the `PCANLight` directory.

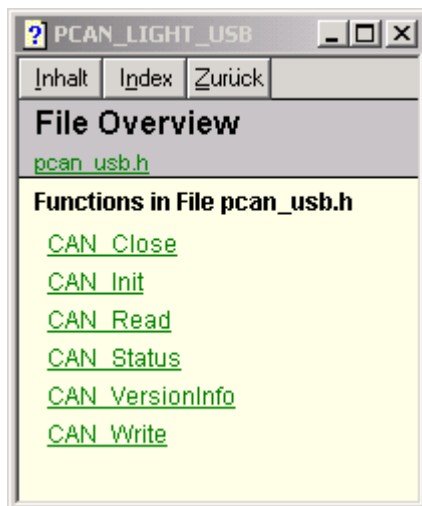

Fig. 8: CAN-function overview

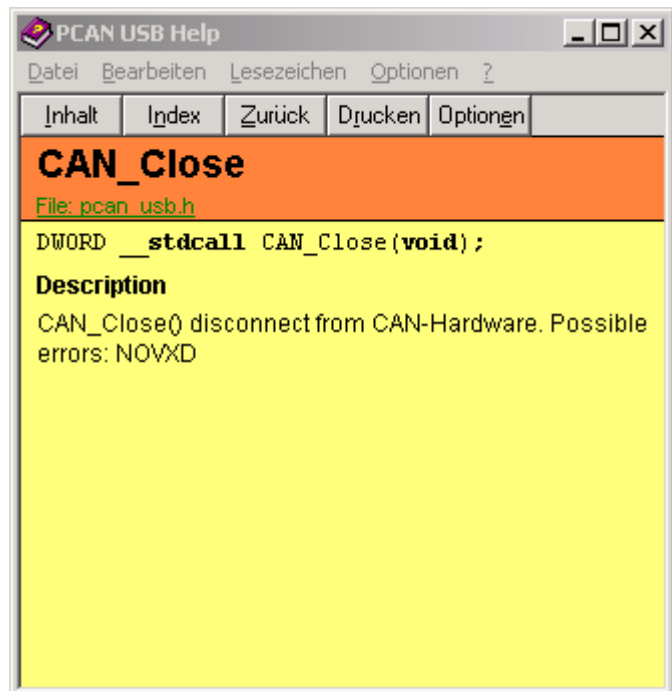

Fig. 9: Description of a CAN-function

4. Connection to the CAN-Bus

The CAN-Net is connected via the 9 pole SUB-D-plug according to CiA recommendation DS102-1. Minimal configurations are the pins 2 and 7 (CAN-L, CAN-H) Reserved pins are not connected.

Pin	Connection
1	Default: not connected / +5 V (through Jumper JP3 or Jumper JP R11)
2	CAN-L
3	CAN-GND
4	not connected
5	not connected
6	CAN-GND
7	CAN-H
8	not connected
9	DEFAULT: not connected / +5 V (through jumper JP3)

Table 1: Connection configuration for the 9 pol. SUB-D plug.

Connector configuration of the SUB-D plug

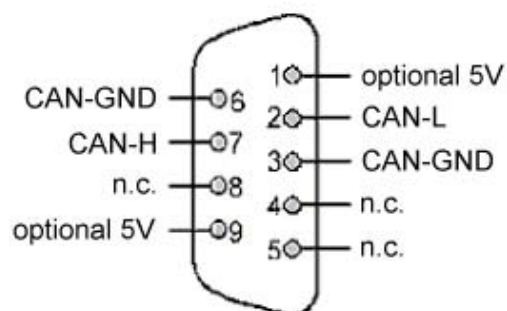

Fig. 10: Connector configuration of the 9 pole SUB-D plug

5. Supply voltage through the SUB-D plug

Through the solder bridge JP3 (or JP R11 if you use an opto-isolated PCAN-USB adaptor), it is possible to give an output voltage of +5V to the 9 pole D-SUB connector. You can choose between the +5V at pin 1 or pin 9 (not by the opto-isolated version). An additional GND is not necessary, pin 3 and pin 6 are permanent connected to GND (see Fig. 10).

ATTENTION!!! The voltage are not safe guarded and would be supplied directly from the USB-port.

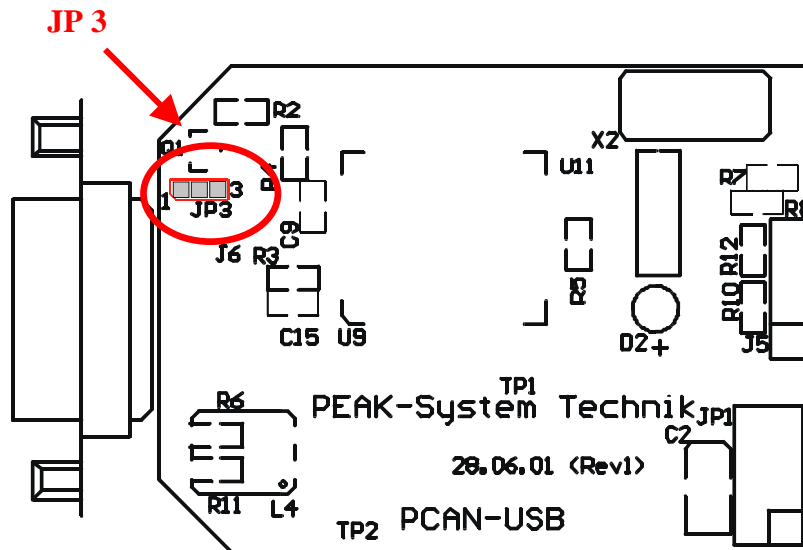

Fig. 11: Jumper position at the PCB for Art.No: IPEH-002021

The figure below shows the necessary solder bridge for a +5V output at pin 1

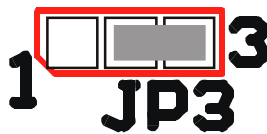

Fig. 12: Necessary connection for the 5V output at pin 1

Note:	5V at pin 9:	Connection between solder pad 1 and solder pad 2.
	5V at pin 1:	Connection between solder pad 2 and solder pad 3.

The opto-isolated PCAN-USB adaptor (Art.-No: IPEH-002022) allows only +5V at pin 1. An additional GND is not necessary, pin 3 and pin 6 are permanent connected to GND.

ATTENTION!!!

The voltage are not safe guarded and would be supplied directly from the USB-port.

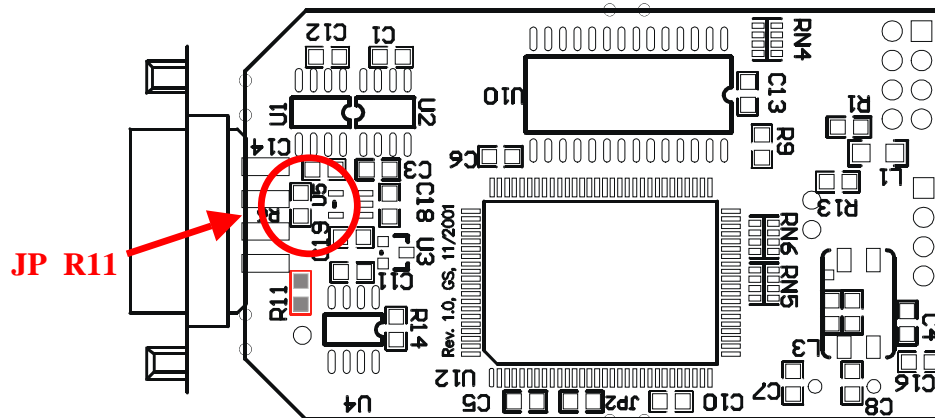

Fig. 12: Jumper position at the PCB for Art.Nr. IPEH-002022 (opto-isolated version)

Note:

5V at pin 1:

Connection between both solder pads.

6. System requirements

- IBM-PC or 100% compatible unit with USB support.
- Windows 98/ME/2000 or XP operating system
- min. 400 MHz Celeron CPU or better
- 64 MB RAM (Windows98/ME), 128MB Windows 2000/XP
- minimum 2 MB free disk space