

# Hardware Manual

**IPC@CHIP Embedded Controller Family  
SC11/SC12/SC13**

High Performance, 80186- and 80188-Compatible,  
16-Bit Embedded Microcontroller  
Single Chip PC with Flash, RAM, Watchdog

Ordering No. IPC @CHIP  
Embedded Controller SC11: 538428  
Embedded Controller SC12: 20040112  
Embedded Controller SC13: 536079



 **gridconnect.**

1841 Centre Point Circle #143  
Naperville, Illinois 60563 USA  
+1 630 245-1445, +1 630 245-1717 FAX  
[www.gridconnect.com](http://www.gridconnect.com)

## Table of Contents

|       |   |    |
|-------|---|----|
| 1.    | BASIC SPECIFICATIONS .....  | 3  |
| 2.    | PHYSICAL DIMENSIONS.....  | 5  |
| 3.    | PIN CONFIGURATION .....   | 7  |
| 4.    | PIN FUNCTIONS .....   | 8  |
| 4.1   | Address / Data bus .....  | 8  |
| 4.2   | Programmable I/O Pins .....                                       | 9  |
| 4.3   | Programmable Chip Selects .....                                   | 10 |
| 4.4   | Interrupts .....  | 10 |
| 4.5   | Timer .....   | 11 |
| 4.6   | 10/100Base-T Interface.....                                       | 11 |
| 4.7   | Asynchronous Serial Ports .....                                   | 12 |
| 4.8   | DMA.....  | 12 |
| 4.9   | Reset, Power Fail Generator.....                                  | 13 |
| 4.10  | NMI-reset-traffic LED sequence SC12 .....                         | 14 |
| 4.11  | NMI-reset-traffic LED sequence SC13.....                          | 15 |
| 4.12  | Startup Pin configuration .....                                   | 16 |
| 5.    | MUTUAL EXCLUSIVE FUNCTIONS .....                                  | 17 |
| 6.    | ETHERNET 10/100BASE-T .....                                       | 18 |
| 6.1   | 10Base-T Media Filter Placement and Termination for SC12 .....    | 18 |
| 6.2   | Magnetics approved for use for 10Base-T application.....          | 18 |
| 6.3   | Routing and placement rules for SC13 and Ethernet components..... | 19 |
| 6.4   | Suggested Magnetics.....  | 19 |
| 7.    | SYSTEM OVERVIEW .....   | 20 |
| 7.1   | Memory map .....  | 20 |
| 7.2   | System interrupts .....   | 21 |
| 7.3   | Watchdog .....  | 21 |
| 8.    | CHARACTERISTICS .....   | 22 |
| 8.1   | ABSOLUTE MAXIMUM RATINGS.....                                     | 22 |
| 8.2   | OPERATING RANGES .....  | 22 |
| 8.3   | DC-CHARACTERISTICS .....  | 23 |
| 8.3.1 | SC12 DC-Characteristics .....                                     | 23 |
| 8.3.2 | SC13/SC11 DC-Characteristics .....                                | 23 |
| 8.4   | AC-CHARACTERISTICS .....  | 24 |
| 8.4.1 | SC12-Read Cycle.....  | 24 |
| 8.4.2 | SC12-Write Cycle.....   | 25 |
| 8.4.3 | SC13/SC11 Read Cycle.....   | 26 |
| 8.4.4 | SC13/SC11 Write Cycle.....  | 27 |
| 9.    | APPLICATION EXAMPLES .....  | 28 |
| 9.1   | NMI / Reset-in / Link-LED .....                                   | 28 |
| 9.2   | Link-LED / Reset .....  | 29 |
| 9.3   | 256x 8bit I/O-Extension using 74HCT573/245.....                   | 29 |
| 9.4   | Connect 10Base-T Ethernet to the SC12.....                        | 30 |
| 9.5   | Connect 10/100Base-T Ethernet to the SC13 .....                   | 31 |
| 9.6   | I <sup>2</sup> C-Bus Example .....                                | 32 |
| 9.7   | SPI-Bus Example .....   | 32 |
| 9.8   | Other Examples.....   | 32 |
| 10.   | CHANGE LIST .....   | 33 |
| 11.   | CONTACT .....   | 34 |

## 1. BASIC SPECIFICATIONS

| @CHIP | CPU             | RAM        | FLASH      | Ethernet     |
|-------|-----------------|------------|------------|--------------|
| SC11  | BECK 186 40MHz  | 512 Kbytes | 512 Kbytes | -            |
| SC12  | AMD 186ED 20MHz | 512 Kbytes | 512 Kbytes | 10Base-T     |
| SC13  | BECK 186 40MHz  | 512 Kbytes | 512 Kbytes | 10/100Base-T |

### **IPC@CHIP® family 80186- and 80188-compatible microcontroller with up to 512KB RAM, 512KB Flash and Ethernet on Chip**

- Lower system cost with higher performance

#### **High performance**

- up to 40MHz operating frequency
- 1 Mbyte internal memory space
- 6 x 256-byte I/O space
- Low-power CMOS process with single 5V power supply

#### **Enhanced integrated peripherals**

- Up to 14 programmable I/O (PIO) pins
- Two full-featured asynchronous serial ports allow full-duplex, 7-bit or 8-bit data transfers, Serial port hardware handshaking with CTS and RTS selectable for each port  
Independent serial port baud rate generators  
DMA to and from the serial ports
- Ethernet controller IEEE 802.3 10Base-T/100Base-TX<sup>1</sup>  
Autonegotiation : 10/100, Full/Half Duplex<sup>2</sup>
- Watchdog timer
- Pulse-width demodulation option

#### **Familiar 80C186 peripherals**

- Two independent DMA channels
- Programmable interrupt controller with up to six external interrupts
- Two programmable 16-bit timers, interrupt capable
- Programmable memory and peripheral chip-select logic

### **Software-compatible with the 80C186 and 80C188 microcontrollers with widely available native development tools, applications, and system software**

#### **Pre-installed Real Time Operating System (@CHIP RTOS)**

#### **Available in the following packages:**

- 32-pin, plastic pack (DIL32)

The Beck IPC@CHIP® family of System on Chip microcontrollers and microprocessors is based on the x86 architecture. The IPC@CHIP® family microcontroller is the ideal solution for new designs requiring Ethernet TCP/IP communication over twisted pair and/or through the serial port. The compatibility with the 80C186/188 family makes it also an ideal upgrade for systems based upon this processor range but requiring increased performance, serial communications, Ethernet communications, a direct bus interface, or more than 64K of memory.

The IPC@CHIP® family microcontrollers integrate up to 512Kbyte RAM with increased performance and up to 512Kbyte FLASH, reducing memory subsystem costs.

The minimum endurance of the Flash memory is 10,000 cycles (depending on environmental stress e.g. temperature).

<sup>1</sup> 10/100BASE-T only for SC13

<sup>2</sup> Autonegotiation only for SC13

The IPC@CHIP® family microcontrollers also integrate the functions of the CPU, multiplexed address bus, three timers, watchdog timer, chip selects, interrupt controller, two DMA controllers, two asynchronous serial ports, and programmable I/O (PIO) pins on one chip.

It also supports I<sup>2</sup>C-Bus and SPI (Serial Peripheral Interface) at any PIO pins via software emulation. The IPC@CHIP® microcontroller is a highly integrated design that provides all Media Access Control (MAC) and Encode-Decode (ENDEC) functions in accordance with the IEEE 802.3 standard. Network interfaces including 10/100Base-T via the Twisted-pair. The integrated 10/100Base-T transceiver makes IPC@CHIP® more cost-effective.

Compared to the 80C186/188 microcontrollers, the IPC@CHIP® family microcontrollers enable designers to reduce the size, power consumption, and cost of embedded systems, while increasing reliability, functionality and performance.

The IPC@CHIP® family microcontrollers have been designed to meet the most common requirements of embedded products developed for the communications, office automation, mass storage, and general embedded markets. Specific applications including industrial controls, data collection, protocol conversion, process monitoring and internet connectivity.

**IPC@CHIP® family microcontroller block diagram**

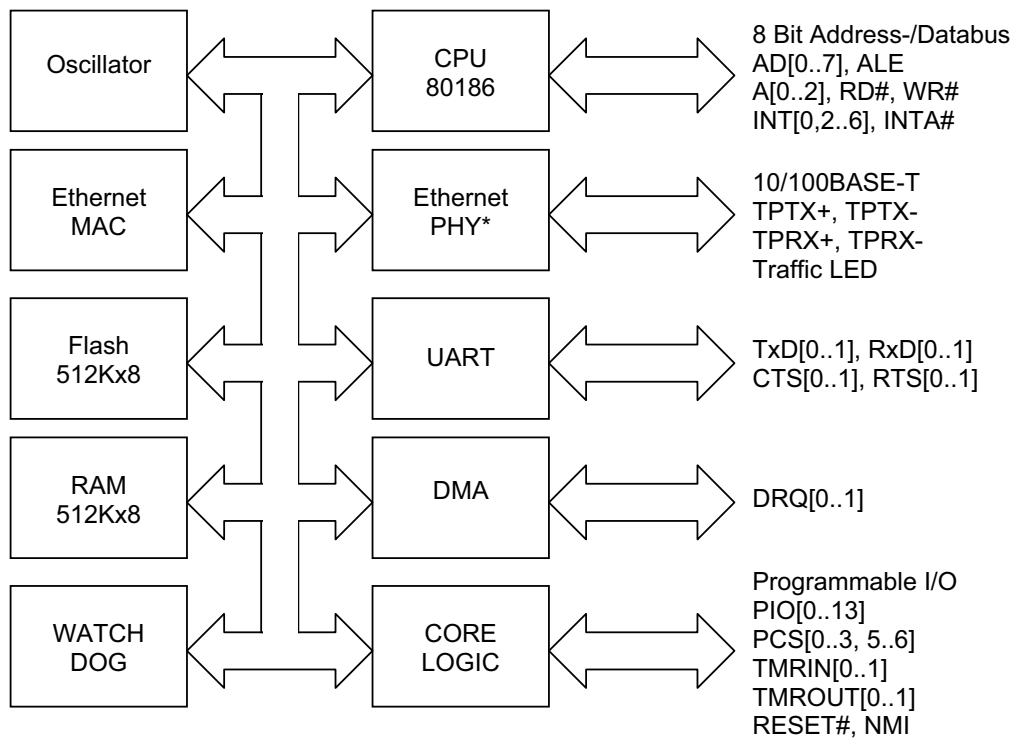

Picture 1.1: Access to hardware components via API functions.  
 \* SC12 and SC13 only

## 2. PHYSICAL DIMENSIONS

The package is physically identical for SC11, SC12 and SC13.

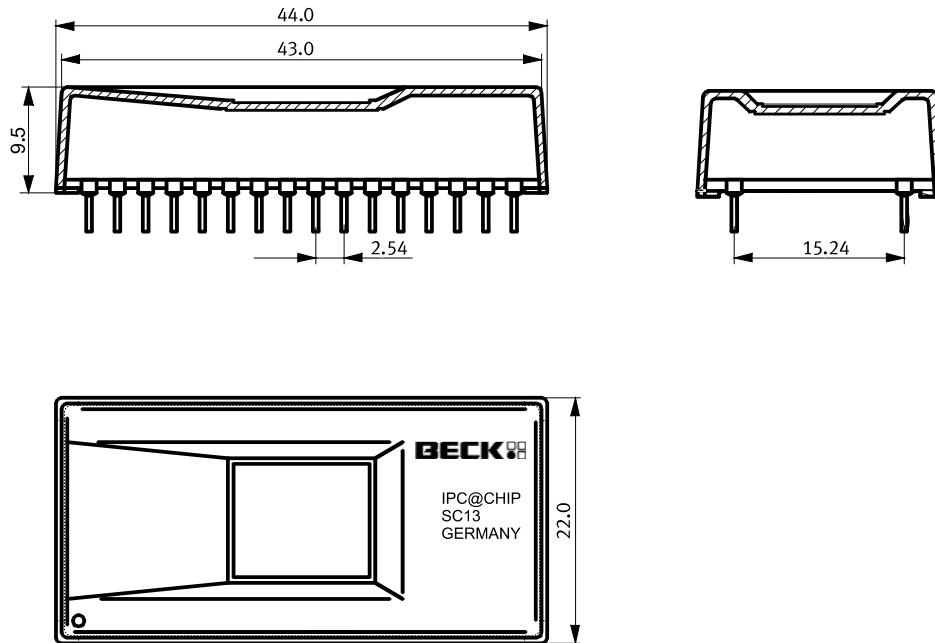

Picture 2.1: IPC@CHIP physical dimensions

### 3. Design and handling guidelines

The IPC@CHIP should be used together with a DIL32 socket.



Electrostatic Sensitive Device

## 4. PIN CONFIGURATION

|                        |    |                 |    |   |
|------------------------|----|-----------------|----|---|
| PIO7 / RXD0            | 1  | <b>IPC@CHIP</b> | 32 | VCC   |
| PIO8 / TXD0            | 2  |                 | 31 | DRQ1 / INT6 / PIO0  |
| PIO9 / CTS0            | 3  |                 | 30 | DRQ0 / INT5 / PIO1  |
| PIO10 / RTS0           | 4  |                 | 29 | A2 / PCS6# / PIO2   |
| PIO11 / TXD1           | 5  |                 | 28 | A1 / PCS5# / TMRIN1 / TMROUT1 / PIO3                            |
| PIO12 / INT3 / RXD1    | 6  |                 | 27 | A0 / PCS1# / TMRIN0 / PIO4                                      |
| PIO13 / INT0 / TMROUT0 | 7  |                 | 26 | RTS1 / PCS3# / INT4 / PIO5                                      |
| AD0                    | 8  |                 | 25 | CTS1 / PCS2# / INT2 / PWD / INTA# / PIO6                        |
| AD1                    | 9  |                 | 24 | ALE / PCS0#   |
| AD2                    | 10 |                 | 23 | WR#   |
| AD3                    | 11 |                 | 22 | RD#   |
| AD4                    | 12 |                 | 21 | TPRX-   |
| AD5                    | 13 |                 | 20 | TPRX+   |
| AD6                    | 14 |                 | 19 | TPTX-   |
| AD7                    | 15 |                 | 18 | TPTX+   |
| GND                    | 16 |                 | 17 | RESET# / NMI / (TRAFFIC_LED) <sup>3</sup> / (LINK) <sup>4</sup> |

Picture 4.1: IPC@CHIP pin configuration

Note: Locate decoupling capacitors as close to VCC Pin as physically possible.

<sup>3</sup> Traffic only SC12 and SC13

<sup>4</sup> Link status only SC12

## 5. PIN FUNCTIONS

### Pin Terminology

The following terms are used to describe the pins:

**Input (I)** - An input-only pin.

**Input (IS)** - An input-only pin with Schmitt Trigger.

**Output (O)** - An output-only pin.

**Input/Output (I/O)** - A pin that can be either input or output.

### 5.1 Address / Data bus

| Pin Name | Type | Function  |
|----------|------|---|
| A[0..2]  | O    | <b>Address Bus (output, three-state)</b><br>These pins supply nonmultiplexed memory or I/O addresses to the system. During a bus hold or reset condition, the address bus is in a high-impedance state.<br>A0–A2 will serve as the nonmultiplexed address bus for external peripherals. A0-A2 covers an address range of 8 Bytes max.   |
| AD[0..7] | I/O  | <b>Multiplexed Address and Data Bus (input/output, three-state, level-sensitive)</b><br>These time-multiplexed pins supply partial memory or I/O addresses, as well as data, to the system. This bus supplies the low-order 8 bits of an address to the system during the first period of a bus cycle (t1), and it supplies data to the system during the remaining periods of that cycle (t2 , t3 , and t4). In 8-bit mode, AD7–AD0 supplies the data for both high and low bytes.<br>During a bus hold or reset condition, the address and data bus is in a high-impedance state. |
| ALE      | O    | <b>Address Latch Enable (output)</b><br>This pin indicates to the system that an address appears on the address and data bus (AD7–AD0). The address is guaranteed to be valid on the trailing edge of ALE.<br>ALE is three-stated and held resistively Low during a bus hold condition. In addition, ALE has a weak internal pulldown resistor that is active during reset, when it is enabled by software.   |
| RD#      | O    | <b>Read Strobe (output, three-state)</b><br>This pin indicates to the system that the microcontroller is performing a memory or I/O read cycle. RD is guaranteed to not be asserted before the address and data bus is floated during the address-to-data transition. RD floats during a bus hold condition.  |
| WR#      | O    | <b>Write Strobe (output)</b><br>This pin indicates to the system that the data on the bus is to be written to a memory or I/O device. WR floats during a bus hold or reset condition.   |

## 5.2 Programmable I/O Pins

| Pin Name   | Type  | Function  |      |   |                            |   |               |        |   |               |        |   |                   |        |   |                   |                   |   |                   |        |   |                   |        |   |                   |        |   |      |        |   |      |        |   |                   |        |    |                   |        |    |      |        |    |      |        |    |                     |          |
|------------|---|---|------|---|----------------------------|---|---------------|--------|---|---------------|--------|---|-------------------|--------|---|-------------------|-------------------|---|-------------------|--------|---|-------------------|--------|---|-------------------|--------|---|------|--------|---|------|--------|---|-------------------|--------|----|-------------------|--------|----|------|--------|----|------|--------|----|---------------------|----------|
| PIO[0..13] | I/O   | <p><b>Programmable I/O Pins (input/output, open-drain)</b><br/>                     The IPC@CHIP® family microcontroller provides 14 individually programmable I/O pins. Each PIO can be programmed with the following attributes: PIO function (enabled/disabled), direction (input/output), and weak pullup or pulldown.</p> <table border="1"> <thead> <tr> <th>PIO#</th> <th>After power-on reset, the PIO pin defaults to</th> <th>Programmable as Input with</th> </tr> </thead> <tbody> <tr><td>0</td><td>Input without</td><td>pullup</td></tr> <tr><td>1</td><td>Input without</td><td>pullup</td></tr> <tr><td>2</td><td>Input with pullup</td><td>pullup</td></tr> <tr><td>3</td><td>Input with pullup</td><td>pullup / pulldown</td></tr> <tr><td>4</td><td>Input with pullup</td><td>pullup</td></tr> <tr><td>5</td><td>Input with pullup</td><td>pullup</td></tr> <tr><td>6</td><td>Input with pullup</td><td>pullup</td></tr> <tr><td>7</td><td>RxD0</td><td>pullup</td></tr> <tr><td>8</td><td>TxD0</td><td>pullup</td></tr> <tr><td>9</td><td>Input with pullup</td><td>pullup</td></tr> <tr><td>10</td><td>Input with pullup</td><td>pullup</td></tr> <tr><td>11</td><td>TxD1</td><td>pullup</td></tr> <tr><td>12</td><td>RxD1</td><td>pullup</td></tr> <tr><td>13</td><td>Input with pulldown</td><td>pulldown</td></tr> </tbody> </table> | PIO# | After power-on reset, the PIO pin defaults to | Programmable as Input with | 0 | Input without | pullup | 1 | Input without | pullup | 2 | Input with pullup | pullup | 3 | Input with pullup | pullup / pulldown | 4 | Input with pullup | pullup | 5 | Input with pullup | pullup | 6 | Input with pullup | pullup | 7 | RxD0 | pullup | 8 | TxD0 | pullup | 9 | Input with pullup | pullup | 10 | Input with pullup | pullup | 11 | TxD1 | pullup | 12 | RxD1 | pullup | 13 | Input with pulldown | pulldown |
| PIO#       | After power-on reset, the PIO pin defaults to | Programmable as Input with  |      |   |                            |   |               |        |   |               |        |   |                   |        |   |                   |                   |   |                   |        |   |                   |        |   |                   |        |   |      |        |   |      |        |   |                   |        |    |                   |        |    |      |        |    |      |        |    |                     |          |
| 0          | Input without                                 | pullup  |      |   |                            |   |               |        |   |               |        |   |                   |        |   |                   |                   |   |                   |        |   |                   |        |   |                   |        |   |      |        |   |      |        |   |                   |        |    |                   |        |    |      |        |    |      |        |    |                     |          |
| 1          | Input without                                 | pullup  |      |   |                            |   |               |        |   |               |        |   |                   |        |   |                   |                   |   |                   |        |   |                   |        |   |                   |        |   |      |        |   |      |        |   |                   |        |    |                   |        |    |      |        |    |      |        |    |                     |          |
| 2          | Input with pullup                             | pullup  |      |   |                            |   |               |        |   |               |        |   |                   |        |   |                   |                   |   |                   |        |   |                   |        |   |                   |        |   |      |        |   |      |        |   |                   |        |    |                   |        |    |      |        |    |      |        |    |                     |          |
| 3          | Input with pullup                             | pullup / pulldown   |      |   |                            |   |               |        |   |               |        |   |                   |        |   |                   |                   |   |                   |        |   |                   |        |   |                   |        |   |      |        |   |      |        |   |                   |        |    |                   |        |    |      |        |    |      |        |    |                     |          |
| 4          | Input with pullup                             | pullup  |      |   |                            |   |               |        |   |               |        |   |                   |        |   |                   |                   |   |                   |        |   |                   |        |   |                   |        |   |      |        |   |      |        |   |                   |        |    |                   |        |    |      |        |    |      |        |    |                     |          |
| 5          | Input with pullup                             | pullup  |      |   |                            |   |               |        |   |               |        |   |                   |        |   |                   |                   |   |                   |        |   |                   |        |   |                   |        |   |      |        |   |      |        |   |                   |        |    |                   |        |    |      |        |    |      |        |    |                     |          |
| 6          | Input with pullup                             | pullup  |      |   |                            |   |               |        |   |               |        |   |                   |        |   |                   |                   |   |                   |        |   |                   |        |   |                   |        |   |      |        |   |      |        |   |                   |        |    |                   |        |    |      |        |    |      |        |    |                     |          |
| 7          | RxD0  | pullup  |      |   |                            |   |               |        |   |               |        |   |                   |        |   |                   |                   |   |                   |        |   |                   |        |   |                   |        |   |      |        |   |      |        |   |                   |        |    |                   |        |    |      |        |    |      |        |    |                     |          |
| 8          | TxD0  | pullup  |      |   |                            |   |               |        |   |               |        |   |                   |        |   |                   |                   |   |                   |        |   |                   |        |   |                   |        |   |      |        |   |      |        |   |                   |        |    |                   |        |    |      |        |    |      |        |    |                     |          |
| 9          | Input with pullup                             | pullup  |      |   |                            |   |               |        |   |               |        |   |                   |        |   |                   |                   |   |                   |        |   |                   |        |   |                   |        |   |      |        |   |      |        |   |                   |        |    |                   |        |    |      |        |    |      |        |    |                     |          |
| 10         | Input with pullup                             | pullup  |      |   |                            |   |               |        |   |               |        |   |                   |        |   |                   |                   |   |                   |        |   |                   |        |   |                   |        |   |      |        |   |      |        |   |                   |        |    |                   |        |    |      |        |    |      |        |    |                     |          |
| 11         | TxD1  | pullup  |      |   |                            |   |               |        |   |               |        |   |                   |        |   |                   |                   |   |                   |        |   |                   |        |   |                   |        |   |      |        |   |      |        |   |                   |        |    |                   |        |    |      |        |    |      |        |    |                     |          |
| 12         | RxD1  | pullup  |      |   |                            |   |               |        |   |               |        |   |                   |        |   |                   |                   |   |                   |        |   |                   |        |   |                   |        |   |      |        |   |      |        |   |                   |        |    |                   |        |    |      |        |    |      |        |    |                     |          |
| 13         | Input with pulldown                           | pulldown  |      |   |                            |   |               |        |   |               |        |   |                   |        |   |                   |                   |   |                   |        |   |                   |        |   |                   |        |   |      |        |   |      |        |   |                   |        |    |                   |        |    |      |        |    |      |        |    |                     |          |

Internal Pullup and Pulldown is approximately 7-10kOhm.

### 5.3 Programmable Chip Selects

| Pin Name  | Type | Function  |
|-----------|------|---|
| PCS[0..3] | O    | <b>Peripheral Chip Selects (output)</b><br>These pins indicate to the system that an I/O memory access is in progress to the corresponding region of the peripheral memory. PCS0–PCS3 are three-stated and held resistively High during a bus hold condition. In addition, PCS0–PCS3 each have a weak internal pullup resistor that is active during reset. The PCS outputs assert with the multiplexed AD address bus. Note also that each peripheral chip select asserts over a 256-byte address range. |
| PCS[5..6] | O    | <b>Peripheral Chip Selects (output)</b><br>These pins indicate to the system that an I/O memory access is in progress to the corresponding region of the peripheral memory. PCS5–PCS6 are three-stated and held resistively High during a bus hold condition. In addition, PCS5–PCS6 each have a weak internal pullup resistor that is active during reset. The PCS outputs assert with the multiplexed AD address bus. Note also that each peripheral chip select asserts over a 256-byte address range. |

### 5.4 Interrupts

| Pin Name   | Type | Function  |
|------------|------|---|
| INT[0,2-6] | I    | <b>Maskable Interrupt Request (input)</b><br>These pins indicate to the microcontroller that an interrupt request has occurred. If the INT pin is not masked, the microcontroller transfers program execution to the location specified by the corresponding INT vector in the microcontroller interrupt vector table.<br>Interrupt requests are synchronised internally and can be edge-triggered or level-triggered. To guarantee interrupt recognition, the requesting device must continue asserting INT until the request is acknowledged. INT2 becomes INTA# when INT0 is configured in cascade mode. |
| INTA#      | O    | <b>Interrupt Acknowledge (output)</b><br>When the microcontroller interrupt control unit is operating in cascade mode, this pin indicates to the system that the microcontroller needs an interrupt type to process the interrupt request on INT0. The peripheral issuing the interrupt request must provide the microcontroller with the corresponding interrupt type.   |
| PWD        | IS   | <b>Pulse Width Demodulator (input, Schmitt trigger)</b><br>If pulse width demodulation is enabled, PWD processes the signal through a Schmitt trigger. PWD is used internally to drive TMRIN0 and INT2, and PWD is inverted internally to drive TMRIN1 and INT4. If INT2 and INT4 are enabled and timer 0 and timer 1 are properly configured, the pulse width of the alternating PWD signal can be calculated by comparing the values in timer 0 and timer 1.<br>In PWD mode, the signals TMRIN0, TMRIN1 and INT4 can be used as PIOs. If they are not used as PIOs, they are ignored internally.          |

## 5.5 Timer

Timer can be clocked internally or externally. Maximum frequency is  $\frac{1}{4}$  CPU clock. If the timer will be clocked internally the timer out pin (TMROUT) may be used. External clock at Input and output at the same time with same timer is not possible.

| Pin Name     | Type | Function   |
|--------------|------|--|
| TMRIN[0..1]  | I    | <b>Timer Input (input, edge-sensitive)</b><br>These pins supply a clock or control signal to the internal microcontroller timer 0 and 1. After internally synchronising a Low-to-High transition on TMRIN, the microcontroller increments the corresponding timer. TMRIN must be tied High if not being used. When PIO is enabled, TMRIN is pulled High internally.<br>TMRIN0 is driven internally by INT2/PWD when pulse width demodulation mode is enabled. The TMRIN0 pin can be used as a PIO when pulse width demodulation mode is enabled. |
| TMROUT[0..1] | O    | <b>Timer Output (output)</b><br>These pins supply the system with either a single pulse or a continuous waveform with a programmable duty cycle.   |

## 5.6 10/100Base-T Interface

| Pin Name                            | Type | Function  |
|-------------------------------------|------|---|
| TPTX[+,-]                           | O    | <b>Twisted Pair Driver (outputs)</b>  |
| TPRX[+,-]                           | I    | <b>Twisted Pair Receive (inputs).</b>   |
| TRAFFIC LED (LINK LED) <sup>5</sup> | O    | <b>Traffic LED Driver (output)</b><br>This pin indicates network traffic by sinking voltage to 3V. It is generated through an open-collector low mode for a short impulse to indicate the presence of traffic on the network. Note that this pin is not able to source any current! |

<sup>5</sup> Link status only SC12

## 5.7 Asynchronous Serial Ports

All asynchronous port pins are TTL level. To provide RS232 or RS485 level external drivers must be connected (like MAX232). The following modes can be provided:

Full-Duplex Operation with 7-bit or 8-bit, odd, even or no parity. Error detection is possible with parity errors, framing errors, overrun errors and break character recognition. Hardware handshaking (Clear-to-send CTS and Request-to-send RTS) is possible.

To get a definite baud rate, a baud rate divider must be provided. A general formula for the baud rate divisor is:  $BAUDDIV = (\text{CPU clock} / (16 \times \text{Baud Rate}))$ . We recommend to using the RTOS function "Get Frequencies".

The maximum baud rate is achieved by setting  $BAUDDIV=0001h$ . This results in a baud rate of 1250Kbit for SC12 and 2500 Kbit for SC11/SC13. A BAUDDIV setting of zero results in no transmission or reception of data.

The serial port receiver tolerance depends on the used settings:

| SC11/SC13             | SC12   |
|-----------------------|--------|
| 9 Bits $\pm 3.47\%$   | + 3.0% |
| 10 Bits $\pm 3.125\%$ | - 2.5% |
| 11 Bits $\pm 2.84\%$  |        |

The two ports can operate at different rates.

| Pin Name  | Type | Function  |
|-----------|------|---|
| TxD[0..1] | O    | <b>Transmit Data (output)</b><br>These pins supply asynchronous serial transmit data to the system from serial port 0 and 1.  |
| RxD[0..1] | I    | <b>Receive Data (input)</b><br>These pins supply asynchronous serial receive data from the system to asynchronous serial ports 0 and 1.   |
| CTS[0..1] | I    | <b>Clear-to-Send (input)</b><br>These pins provide the Clear-to-Send signal for asynchronous serial port 0 and 1 when hardware flow control is enabled for the port. The CTS signals gate the transmission of data from the associated serial port transmit register. When CTS is asserted, the transmitter begins transmission of a frame of data, if any is available. If CTS is deasserted, the transmitter holds the data in the serial port transmit register. The value of CTS is checked only at the beginning of the transmission of the frame. |
| RTS[0..1] | O    | <b>Request-to-Send 0 (output)</b><br>These pins provide the Request-to-Send signal for asynchronous serial ports 0 and 1 when hardware flow control is enabled for the port. The RTS signals are asserted when the associated serial port transmit register contains data that has not been transmitted.  |

## 5.8 DMA

| Pin Name  | Type | Function   |
|-----------|------|--|
| DRQ[0..1] | I    | <b>DMA Request (input, level-sensitive)</b><br>These pins indicate to the microcontroller that an external device is ready for DMA channel 0 or 1 to perform a transfer. DRQ is level-triggered and internally synchronised. DRQ is not latched and must remain active until serviced. |

## 5.9 Reset, Power Fail Generator

Note that RESET# pin shares 3(4) functions: RESET and NMI as described here, as well as network traffic (and link status for SC12) as described in the corresponding chapters.

This is a voltage-multiplexed pin that internally sinks current in the case of a ethernet packet send/receive. All peripheral logic asserted to this pin must be open-collector to prevent the internal logic from sinking too high current. The pin is already provided with an internal pullup resistor.

|      | $R_{pullup}$ |
|------|--------------|
| SC11 | 4.7 kOhm     |
| SC12 | 1 kOhm       |
| SC13 | 4.7 kOhm     |

| Pin Name | Type | Function   |
|----------|------|--|
| RESET#   | I    | <b>Reset (input/level-sensitive)</b><br>If voltage on this pin goes below 0.8V the microcontroller will perform a reset. In that case the microcontroller immediately terminates its present activity, clears its internal logic, and transfers CPU control to the reset address.  |
| NMI      | I    | <b>Nonmaskable Interrupt (input, level-sensitive)</b><br>If voltage on this pin goes down below VNMIRT (see DC CHARACTERISTICS) it indicates to the microcontroller that an interrupt request has occurred. The NMI signal is the highest priority hardware interrupt and, unlike the INT6–INT0 pins, cannot be masked. The microcontroller always transfers program execution to the location specified by the nonmaskable interrupt vector in the microcontroller interrupt vector table when NMI is asserted.<br>The NMI is for detecting low supply power and the following data backup only. A reset has to follow after the NMI. To guarantee that the interrupt is recognised, the NMI condition must be asserted to the pin until reset. |

The following schematic delivers a principle insight of pin 17.

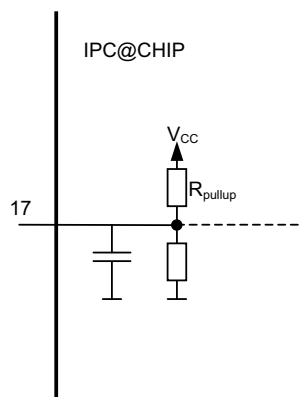

### 5.10 NMI reset traffic LED sequence SC12

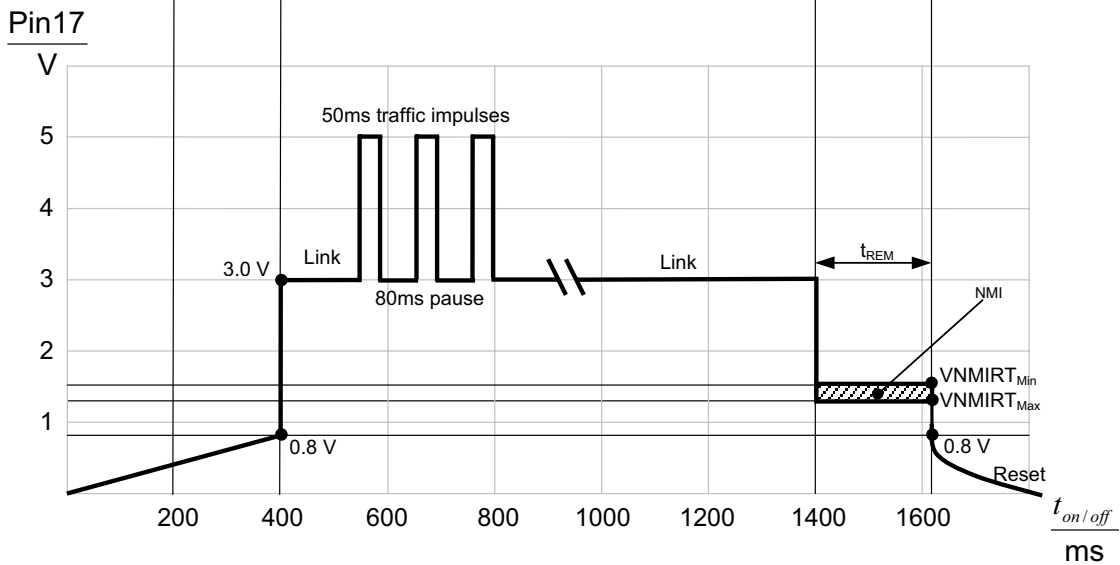
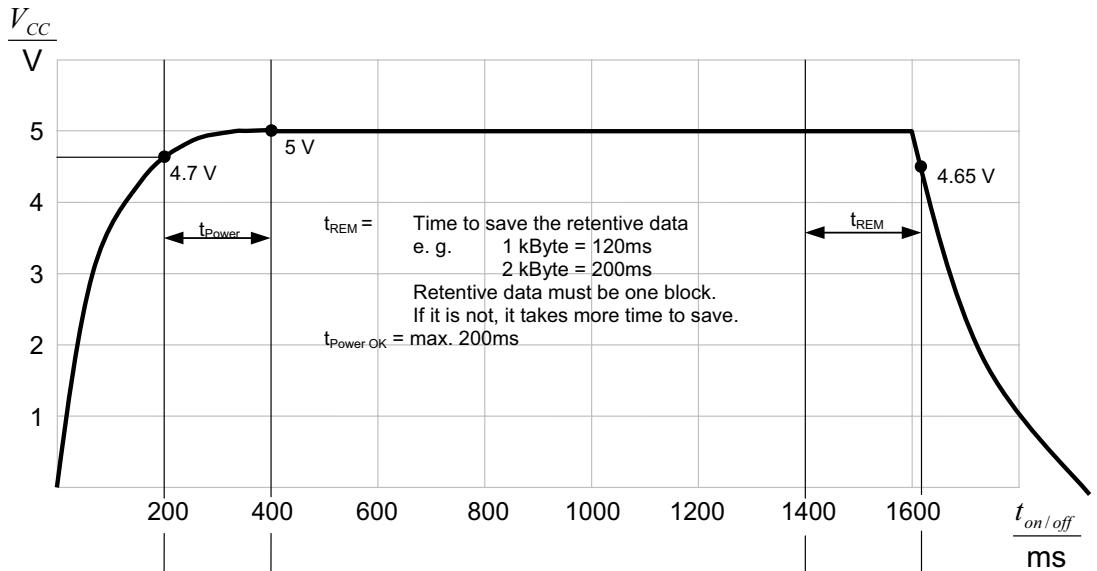

To implement time to save the retentive data keep Pin 17 at  $V_{NMIRT}^6$  and VCC at 5V for  $t_{REM}$  with external capacitors. If Pin 17 goes below 0.8V IPC@CHIP will be in reset state.

<sup>6</sup> see DC-Characteristics

### 5.11 NMI reset traffic LED sequence SC13

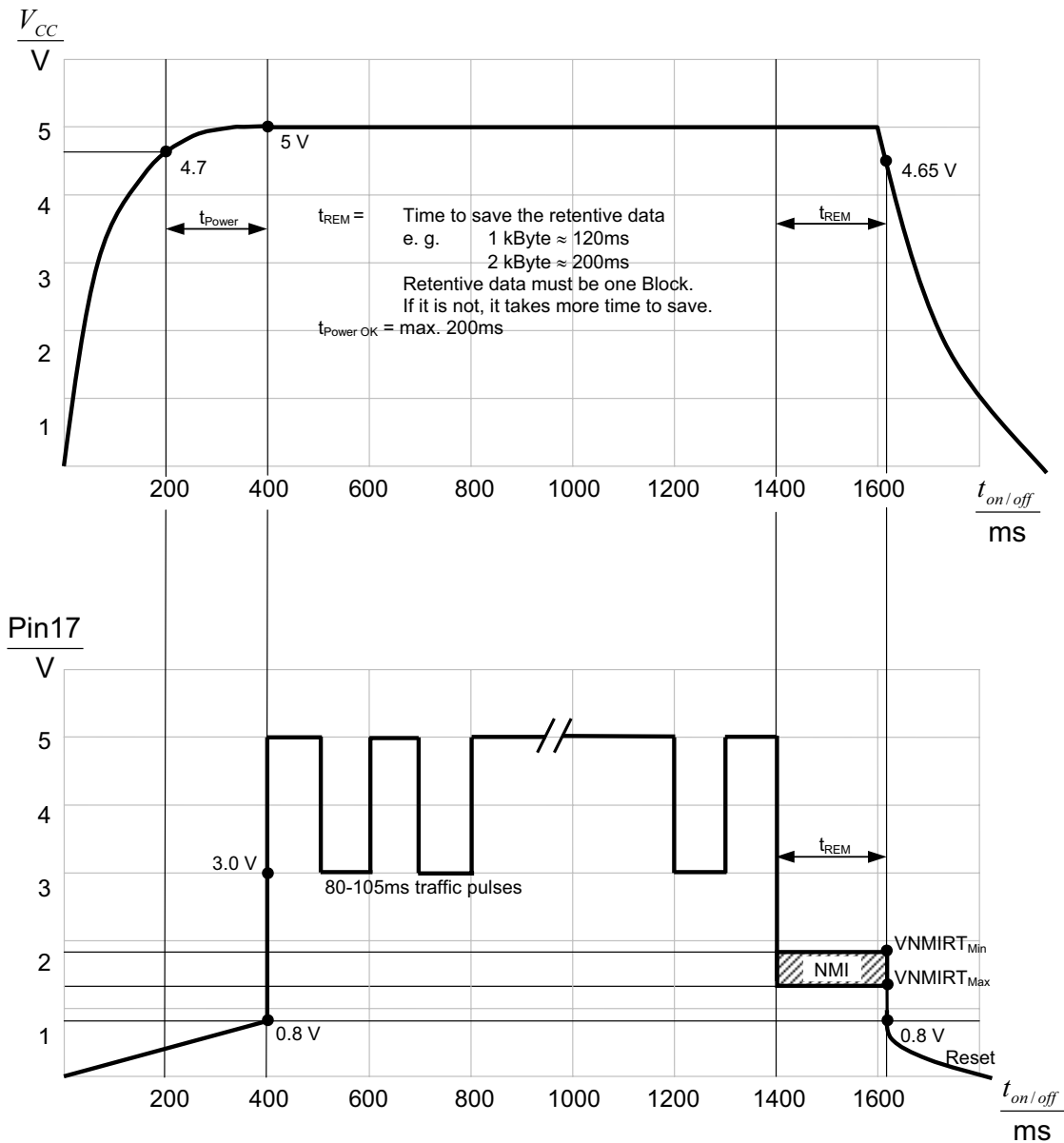

To implement time to save the retentive data keep Pin 17 at  $V_{NMIRT}^7$  and  $V_{CC}$  at 5V for  $t_{REM}$  with external capacitors. If Pin 17 goes below 0.8V IPC@CHIP will be in reset state.

<sup>7</sup> see DC Characteristics

## 5.12 Startup Pin configuration

At turn-on the IPC@Chip I/O pins are configured as follows:

- Pin1: RXD0/PIO7 = RXD0
- Pin2: TXD0/PIO8 = TXD0
- Pin3: CTS0/PIO9 = Input pullup
- Pin4: RTS0/PIO10 = Input pullup
- Pin5: TXD1/PIO11 = TXD1
- Pin6: RXD1/PIO12 = RXD1
- Pin7: TMROUT0/INT0/PIO13 = Input pulldown
- Pin17: RESET/NMI/TRAFFIC = Input
- Pin24: ALE/PCS0 = Output, value 1
- Pin25: CTS1/PCS2/PIO6/INT2 = Input pullup
- Pin26: RTS1/PCS3/PIO5/INT4 = Input pullup
- Pin27: PCS1/PIO4/TMRIN0/A0 = Input pullup
- Pin28: PCS5/PIO3/TMROUT1/TMRIN1/A1 = Input pullup
- Pin29: PCS6/PIO2/A2 = Input pullup
- Pin30: INT5/PIO1 = Input
- Pin31: INT6/PIO0 = Input

## 6. MUTUALLY EXCLUSIVE FUNCTIONS

The IPC@CHIP® family microcontroller provides a lot of different functions by several multi-function pins. Choosing one function will result in disabling other functions. The following table shows, which functions are mutually exclusive.

| Pin Name                 | Function                            | Exclusion  |
|--------------------------|-------------------------------------|--|
| A0                       | nonmultiplexed address A0           | PIO4, PCS1#, TMRIN0  |
| A[1..2]                  | nonmultiplexed address A[1..2]      | PIO[2..3], PCS[5..6], Timer 1  |
| ALE                      | Address / Data bus                  | PCS0#  |
| CTS0                     | hardware flow control Serial Port 0 | PIO9   |
| CTS1                     | hardware flow control Serial Port 1 | PIO6, PCS2#, INT2, INTA#, PWD  |
| DRQ0                     | DMA Request 0                       | PIO1, INT5   |
| DRQ1                     | DMA Request 1                       | PIO0, INT6   |
| INT0                     | Interrupt Request 0                 | PIO13, TMROUT0, cascaded Interrupt Controller  |
| INT2                     | Interrupt Request 2                 | PIO6, PCS2#, INTA#, PWD, hardware flow control Serial Port 1   |
| INT3                     | Interrupt Request 3                 | PIO12, Serial Port 1   |
| INT4                     | Interrupt Request 4                 | PIO5, PCS3#, SPI, hardware flow control Serial Port 1  |
| INT5                     | Interrupt Request 5                 | PIO1, DRQ0   |
| INT6                     | Interrupt Request 6                 | PIO0, DRQ1   |
| INTA#                    | cascaded Interrupt Controller       | PIO6, PIO13, INT0, INT2, PCS2#, PWD, TMROUT0, HW flow control Serial Port 1  |
| PWD                      | Pulse Width Demodulator             | PIO6, PCS2, INT2, INT4, TMROUT[0..1], TMRIN[0..1], INTA#, cascaded Interrupt Controller, HW flow control Serial Port 1 |
| PCS0#                    | programmable chip select 0          | Address/Data bus   |
| PCS1#                    | programmable chip select 1          | A0, PIO4, TMRIN0   |
| PCS2#                    | programmable chip select 2          | PIO6, INT2, INTA#, PWD, HW flow control Serial Port 1, cascaded Interrupt Controller                                   |
| PCS3#                    | programmable chip select 3          | PIO5, INT4, hardware flow control Serial Port 1  |
| PCS5#                    | programmable chip select 5          | A[1..2], PIO3, Timer 1   |
| PCS6#                    | programmable chip select 6          | A[1..2], PIO2  |
| PIO0                     | Programmable I/O                    | DRQ1, INT6   |
| PIO1                     | Programmable I/O                    | DRQ0, INT5   |
| PIO2                     | Programmable I/O                    | A2, PCS6#  |
| PIO3                     | Programmable I/O                    | A1, PCS5#, Timer 1   |
| PIO4                     | Programmable I/O                    | A0, PCS1#, TMRIN0  |
| PIO5                     | Programmable I/O                    | PCS3#, INT4, hardware flow control Serial Port 1   |
| PIO6                     | Programmable I/O                    | PCS2#, INT2, cascaded Interrupt Controller, PWD, HW flow control Serial Port 1   |
| PIO7                     | Programmable I/O                    | Serial Port 0  |
| PIO8                     | Programmable I/O                    | Serial Port 0  |
| PIO9                     | Programmable I/O                    | Hardware flow control Serial Port 0  |
| PIO10                    | Programmable I/O                    | Hardware flow control Serial Port 0  |
| PIO11                    | Programmable I/O                    | Serial Port 1  |
| PIO12                    | Programmable I/O                    | Serial Port 1, INT3  |
| PIO13                    | Programmable I/O                    | INT0, cascaded Interrupt Controller, TMROUT0   |
| RxD0, TxD0               | Serial Port 0 w/o HW flow control   | PIO[7..8]  |
| RxD0, TxD0<br>CTS0, RTS0 | Serial Port 0 with HW flow control  | PIO[7..10]   |
| RxD1, TxD1               | Serial Port 1 w/o HW flow control   | PIO[11..12], INT3  |
| RxD1, TxD1<br>CTS1, RTS1 | Serial Port 1 with HW flow control  | PIO[5..6,11..12], INT3, PCS[2..3]#, INT2, INT4, PWD, cascaded Interrupt Controller                                     |

## 7. ETHERNET 10/100BASE-T

### 7.1 10Base-T Media Filter Placement and Termination for SC12

Placement of the termination components TPTX+ and TPTX- should be located as physically close to the media filter as possible.

The media filter should also be placed as physically close to the RJ-45 connector as possible to minimise stray EMI transfer to the media. The trace routing is to keep the area enclosed by a circuit loop as small as possible to minimise the incidence of magnetic coupling. However this can conflict with the general rule of keeping trace lengths to a minimum. For example, if circuit components are positioned along the same sides of a square, the best return is back along the same three sides of the square, NOT directly back along the fourth side. This rule must be strictly adhered to. Furthermore, there should never be an unnecessary feed-through inside the circuit loop. This also implies that the circuit loop should never encircle the power/ground planes (i.e. part of the circuit loop above and part of circuit loop below these planes).

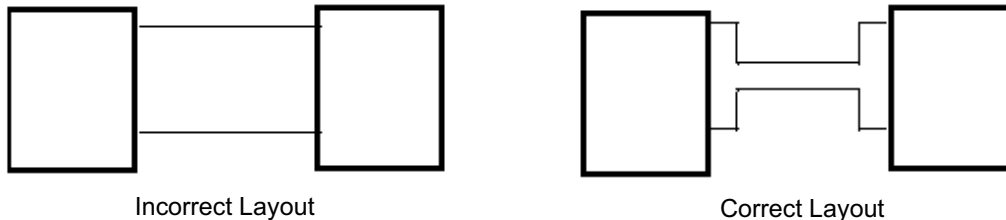

The two traces of the pair should always be routed in adjacent channels and should be of same length. To reduce capacitive coupling, each circuit loop should be separated from the others. Circuit loops can be separated either by physical space (if located on the same layer) or by placement of signal layers on the opposite side of the power/ground planes. The following signal groups should be isolated from each other. Width of receiver trace should be 25 mil minimum to achieve 50Ohm impedance characteristic at 10MHz. Width of transmitter trace should be 10 mil minimum to achieve 250Ohm impedance characteristic at 10MHz. To achieve optimum performance the designer must protect the magnetics from the environment. It should be isolated from the power and ground planes.

### 7.2 Magnetics approved for use for 10Base-T application

#### Through-Hole PCB:

BEL FUSE, Inc. part no. 0556-5999-19 (<http://www.belfuse.com>)  
Halo Electronics, Inc. Part no. FS22-101Y4 (<http://www.haloelectronics.com>)  
BECK-IPC GmbH Part no. FS22-101Y4 (online shop ordering number 20003276)  
Valor, Inc. part no. FL1012/1066 (<http://www.valorinc.com/>)

#### Surface-Mount PCB:

Valor, Inc. part no. SF1012 (<http://www.valorinc.com/>)

### 7.3 Routing and placement rules for SC13 and Ethernet components

1. Place the RJ45 connector, the magnetics and the SC13 as close together as possible.
2. If No. 1 is not possible, keep the RJ45 and the magnetics as close as possible. This will allow remote placement of the SC13.
3. Select and place the magnetics as the best routing scheme from the SC13 to the magnetics to the RJ45 connector.
4. Place the  $49.9\Omega$  TX termination pull-ups (TPTX+/TPTX-, pin 18/19) as close to the magnetics as possible.
5. Place the two  $24.9\Omega$  RX series resistors as close to the magnetics as possible.
6. Place the two  $24.9\Omega$  RX termination resistors and the 10 nF capacitor ( TPRX+, pin 20 & TPRX-, pin 21) as close to the SC13 as possible.
7. Place the  $75\Omega$  cable side center tap termination resistors and the 1nF capacitor as close to the magnetics as possible.
8. Place the Unused Wire Pair termination resistors and the 1nF capacitor as close to the RJ45 connector as possible.
9. The traces connecting the transmit outputs (TPTX+, pin 18) & (TPTX-, pin 19) to the magnetics must be run as differential pairs. The differential impedance should be 100 ohms.
10. The traces connecting the transmit outputs from the magnetics to pins 1 & 2 on the RJ45 connector must be run as differential pairs. The differential impedance should be 100 ohms.
11. The traces connecting the receive inputs (TPRX+, pin 20) & (TPRX-, pin 21) from the magnetics must be run as differential pairs. The differential impedance should be 100 ohms.
12. The traces connecting the receive inputs on the magnetics from pins 3 & 6 on the RJ45 connector must be run as differential pairs. The differential impedance should be 100 ohms.
13. Typically, all planes are cleared out from under the differential pairs connecting the RJ45 and the magnetics. The plane clear out boundary is usually halfway through the magnetics.
14. Trace impedance depends upon many variables (PCB construction, trace width, trace spacing, etc.). The electrical engineer needs to work with the PCB designer to determine all these variables.
15. Try to keep all other signals out of the Ethernet front end (RJ45 through the magnetics to the IPC@CHIP). Any noise from other traces may couple into the Ethernet section and cause problems.

### 7.4 Suggested Magnetics

#### Surface-Mount PCB:

BECK-IPC GmbH    Part no. Magnetic FS23                      (online shop ordering number: 538431)  
Halo Electronics, Inc.    Part no. TG110-S050N2                      (<http://www.haloelectronics.com>)

#### Through-Hole PCB:

BECK-IPC GmbH    Part no. Magnetic Module FM23    (online shop ordering number: 538430)

## 8. SYSTEM OVERVIEW

### 8.1 Memory map

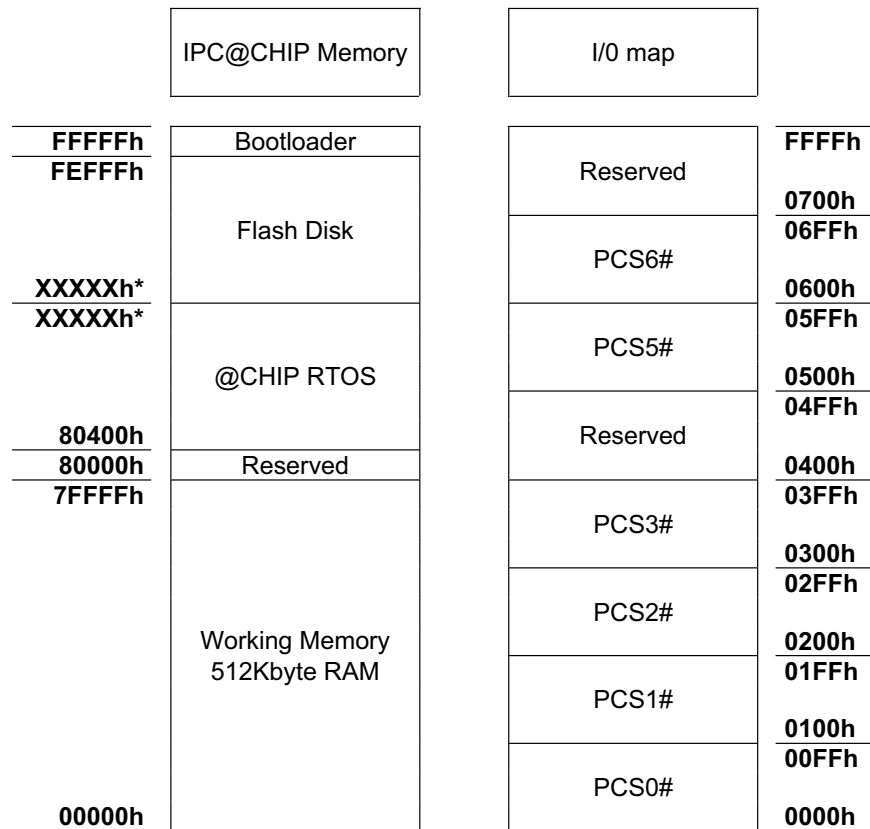

picture 8.1: IPC@CHIP memory map

\* depends on the CHIP-RTOS version, see "Scaled @Chip-RTOS versions" in @CHIP-RTOS API Documentation

## 8.2 System interrupts

| Source   | Sensitivity  |
|--|--------------|
| INT0 (external)  | Edge / Level |
| Network controller (internal)                              |              |
| INT2 (external)  | Edge / Level |
| INT3 (external)  | Edge / Level |
| INT4 (external)  | Edge / Level |
| INT5 (external) / DMA Interrupt Channel 0 (if DMA is used) | Edge         |
| INT6 (external) / DMA Interrupt Channel 1 (if DMA is used) | Edge         |
| Reserved   |              |
| Timer0 (internal)  |              |
| Timer1 (internal)  |              |
| Timer 1ms (internal) (*)                                   |              |
| Serial port 0 (internal) (*)                               |              |
| Serial port 1 (internal) (*)                               |              |
| NMI (internal/external)                                    |              |

(\*) Internal used by @CHIP-RTOS, not available for user interrupt service functions

When an interrupt occurs all interrupts are disabled until the interrupts are released by setting IF Flag in the interrupt service routine. Interrupts of the same source are masked until the corresponding Bit in interrupt service register is cleared.

Level sensitive interrupts are triggered by a high level, edge sensitive interrupts by the rising edge.

## 8.3 Watchdog

The IPC@CHIP provides a true watchdog timer function. The watchdog can be used to regain control of the system when software fails to respond as expected. The watchdog is active after reset. The watchdog timeout period is about 838 ms. The mode can set to trigger the watchdog by the user program or by the CHIP-RTOS (default). In CHIP-RTOS mode, the CHIP-RTOS performs the watchdog strobing provided that the system's timer interrupt is allowed to execute. Beware that excessive interrupt masking periods can lead to system resets.

## 9. CHARACTERISTICS

### 9.1 ABSOLUTE MAXIMUM RATINGS

|   | <b>SC11</b>              | <b>SC12</b>              | <b>SC13</b>              |
|---|--------------------------|--------------------------|--------------------------|
| Storage temperature                       | -25°C to +100°C          | -25°C to +100°C          | -25°C to +100°C          |
| Supply voltage ( $V_{CC}$ )               | -0.3V to +6.0V           | -0.3V to +6.0V           | -0.3V to +6.0V           |
| Supply current ( $V_{CC} = 5.25V$ )       | 240mA                    | 220 mA                   | 400 mA                   |
| Voltage on any pin with respect to ground | -0.3V to $V_{CC} + 0.3V$ | -0.3V to $V_{CC} + 0.3V$ | -0.3V to $V_{CC} + 0.3V$ |

### 9.2 OPERATING RANGES

|   | <b>SC11</b>  | <b>SC12</b>  | <b>SC13</b>  |
|---|--------------|--------------|--------------|
| Operating temperature (Ambient $T_A$ )      | 0°C to +70°C | 0°C to +70°C | 0°C to +70°C |
| Supply voltage ( $V_{CC}$ )                 | 5.0V +/- 5%  | 5.0V +/- 5%  | 5.0V +/- 5%  |
| Typical power supply current (at $V_{CC}$ ) | 180mA        | 180mA        | 300mA        |

Note: Exposure to conditions beyond those listed here may adversely affect the lifetime and reliability of the device.

### 9.3 DC CHARACTERISTICS

(Under operating ranges unless otherwise noted)

#### 9.3.1 SC12 DC Characteristics

| Symbol          | Parameter Description               | Test Condition | MIN. | TYP. | MAX. | Unit |
|-----------------|-------------------------------------|----------------|------|------|------|------|
| I <sub>CC</sub> | Current into V <sub>CC</sub>        |                |      | 180  | 220  | mA   |
| VOL             | Voltage Output Low                  | IOL = 2.0mA    | -    |      | 0.45 | V    |
| VOH             | Voltage Output High                 | IOH = -0.4mA   | 2.4  |      | -    | V    |
| VILO            | Voltage Input Low                   | -              | -    |      | 0.8  | V    |
| VIHI            | Voltage Input High                  | -              | 2.0  |      | -    | V    |
| VRT             | Reset Threshold                     |                | 4.5  | 4.65 | 4.75 | V    |
|                 | Reset Threshold Hysteresis          |                |      | 0.04 |      | V    |
| VRESLO          | IN Voltage Reset active             |                | 0    |      | 0.8  | V    |
| VRESOL          | OUT Voltage Reset Low               | IOL = -9mA     |      |      | 0.8  | V    |
| VNMIRT          | NMI Threshold                       | VCC = 5V       | 1.3  |      | 1.5  | V    |
| Clout           | External Load on AD[0..7], RD#, WR# |                |      |      | 20   | PF   |
|                 | External Load on the other pins     |                |      |      | 30   | PF   |
| Clin            | Input Capacitance                   |                |      |      | 30   | PF   |
| RPIO            | Internal Pullup/-down Resistor      |                |      | 10K  |      | Ω    |

#### 9.3.2 SC13/SC11 DC Characteristics

| Symbol          | Parameter Description               | Test Condition | MIN. | TYP. | MAX. | Unit |
|-----------------|-------------------------------------|----------------|------|------|------|------|
| I <sub>CC</sub> | Current into V <sub>CC</sub>        | SC11           |      | 180  | 220  | mA   |
| I <sub>CC</sub> | Current into V <sub>CC</sub>        | SC13           |      | 300  | 400  | mA   |
| VOL             | Voltage Output Low                  | IOL = 4.0mA    | -    |      | 1.5  | V    |
| VOH             | Voltage Output High                 | IOH = -4.0mA   | 3.5  |      | -    | V    |
| VILO            | Voltage Input Low                   | -              | -    |      | 1.5  | V    |
| VIHI            | Voltage Input High                  | -              | 3.5  |      | -    | V    |
| VRT             | Reset Threshold                     |                | 4.5  | 4.65 | 4.75 | V    |
|                 | Reset Threshold Hysteresis          |                |      | 0.04 |      | V    |
| VRESLO          | IN Voltage Reset active             |                | 0    |      | 0.8  | V    |
| VRESOL          | OUT Voltage Reset Low               | IOL = -4mA     |      |      | 0.8  | V    |
| VNMIRT          | NMI Threshold                       | VCC = 5V       | 1.3  |      | 1.8  | V    |
| Clout           | External Load on AD[0..7], RD#, WR# |                |      |      | 20   | PF   |
|                 | External Load on the other pins     |                |      |      | 30   | PF   |
| Clin            | Input Capacitance                   |                |      |      | 30   | PF   |
| RPIO            | Internal Pullup/-down Resistor      |                | 7K   |      | 10K  | Ω    |



**9.4.2 SC12 Write Cycle**

T<sub>A</sub> = 25°C

| No.                                 | Symbol             | Description                      | Min                   | Max | Unit |
|-------------------------------------|--------------------|----------------------------------|-----------------------|-----|------|
| <b>General Timing Responses</b>     |                    |                                  |                       |     |      |
| 10                                  | t <sub>LHLL</sub>  | ALE Width                        | 40                    |     | ns   |
| 12                                  | t <sub>AVLL</sub>  | AD Address Valid to ALE Low      | 23                    |     | ns   |
| 17                                  | T <sub>CXCSX</sub> | PCSx# Hold from Read Inactive    | 23                    |     | ns   |
| 23                                  | T <sub>LHAV</sub>  | ALE High to Address Valid        | 20                    |     | ns   |
| 99                                  | T <sub>PLAL</sub>  | PCSx# Active to ALE Inactive     | 15                    | 28  | ns   |
| <b>Write Cycle Timing Responses</b> |                    |                                  |                       |     |      |
| 32 <sub>a</sub>                     | T <sub>WLWH</sub>  | Write Pulse Width (PCS0#..PCS3#) | 90 + X <sup>(1)</sup> |     | ns   |
| 32 <sub>b</sub>                     | T <sub>WLWH</sub>  | Write Pulse Width (PCS5#, PCS6#) | 240                   |     | ns   |
| 33                                  | T <sub>WHLH</sub>  | Write Inactive to ALE High       | 23                    |     | ns   |
| 34                                  | T <sub>WHDX</sub>  | Data Hold after Write Inactive   | 40                    |     | ns   |

<sup>(1)</sup>X depends on wait states of PCS0#..PCS3# and can be 0..750ns (see @CHIP-RTOS Doc.)

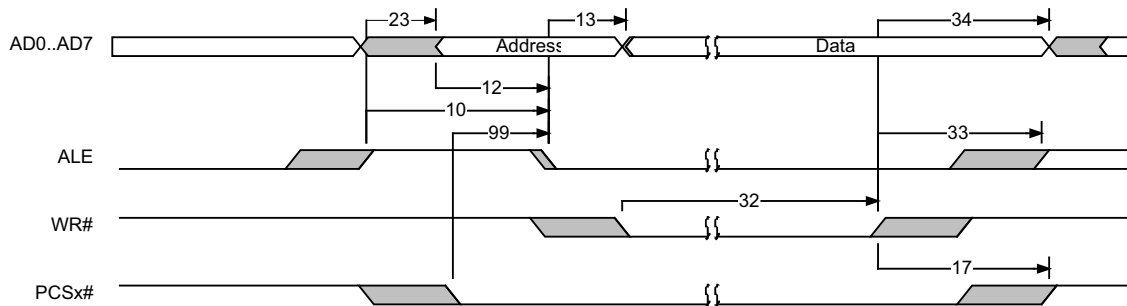

\*) the falling edge of PCS0# is 50ns delayed internally

**9.4.3 SC13/SC11 Read Cycle**

T<sub>A</sub> = 25°C

| No.                                | Symbol             | Description                             | Min                   | Max                   | Unit |
|------------------------------------|--------------------|---|-----------------------|-----------------------|------|
| <b>General Timing Requirements</b> |                    |   |                       |                       |      |
| 1 <sub>a</sub>                     | t <sub>RLDV</sub>  | Read Valid to Data Valid (PCS0#..PCS3#) | 12                    | 12 + X <sup>(1)</sup> | ns   |
| 1 <sub>b</sub>                     | t <sub>RLDV</sub>  | Read Valid to Data Valid (PCS5#, PCS6#) | 12                    | 12 + X <sup>(1)</sup> | ns   |
| 59                                 | t <sub>RHDX</sub>  | Read Inactive to Data Hold on AD Bus    | 0                     |                       | ns   |
| <b>General Timing Responses</b>    |                    |   |                       |                       |      |
| 10                                 | t <sub>LHLL</sub>  | ALE Width                               | 20                    |                       | ns   |
| 12                                 | t <sub>AVLL</sub>  | AD Address Valid to ALE Low             | 10                    |                       | ns   |
| 13                                 | t <sub>LLAX</sub>  | AD Address Hold from ALE Inactive       | 10                    |                       | ns   |
| 17                                 | t <sub>CXCSX</sub> | PCSx# Hold from Command Inactive        | 20                    |                       | ns   |
| 23                                 | t <sub>LHAV</sub>  | ALE High to Address Valid               | 10                    |                       | ns   |
| 99                                 | t <sub>PLAL</sub>  | PCSx# Active to ALE Inactive            | 23                    | 30                    | ns   |
| <b>Read Cycle Timing Responses</b> |                    |   |                       |                       |      |
| 24                                 | t <sub>AZRL</sub>  | AD Address Float to Read Active         | 0                     |                       | ns   |
| 26 <sub>a</sub>                    | t <sub>RLRH</sub>  | Read Pulse Width (PCS0#..PCS3#)         | 20 + X <sup>(1)</sup> |                       | ns   |
| 26 <sub>b</sub>                    | t <sub>RLRH</sub>  | Read Pulse Width (PCS5#, PCS6#)         | 20 + X <sup>(1)</sup> |                       | ns   |
| 28                                 | t <sub>RHLH</sub>  | Read Inactive to ALE High               | 10                    |                       | ns   |
| 29                                 | t <sub>RHAV</sub>  | Read Inactive to AD Address Active      | 20                    |                       | ns   |

<sup>(1)</sup>X depends on wait states and can be 0.. 6375ns. (see @CHIP-RTOS Doc)

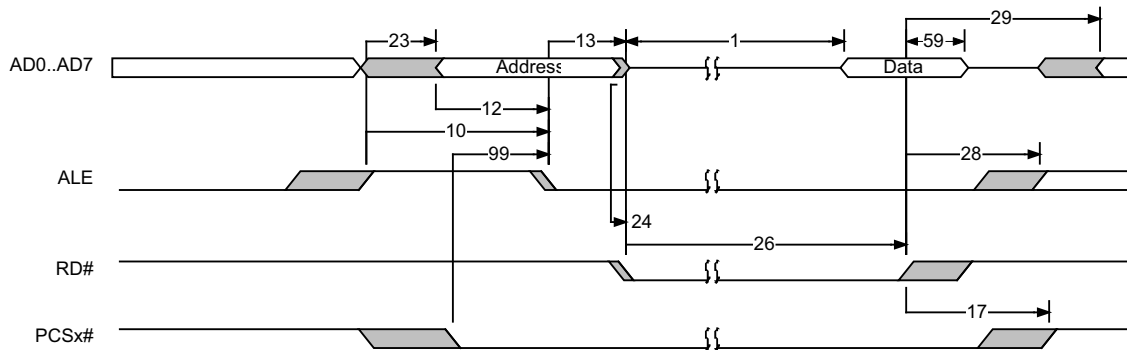

\*) the falling edge of PCS0# is 25ns delayed internally

**9.4.4 SC13/SC11 Write Cycle**

T<sub>A</sub> = 25°C

| No.                                 | Symbol             | Description                       | Min                   | Max | Unit |
|-------------------------------------|--------------------|-----------------------------------|-----------------------|-----|------|
| <b>General Timing Responses</b>     |                    |                                   |                       |     |      |
| 10                                  | t <sub>LHLL</sub>  | ALE Width                         | 20                    |     | ns   |
| 12                                  | t <sub>AVLL</sub>  | AD Address Valid to ALE Low       | 10                    |     | ns   |
| 13                                  | t <sub>LLAX</sub>  | AD Address Hold from ALE Inactive | 10                    |     | ns   |
| 17                                  | t <sub>CXCSX</sub> | PCSx# Hold from Command Inactive  | 20                    |     | ns   |
| 23                                  | t <sub>LHAV</sub>  | ALE High to Address Valid         | 10                    |     | ns   |
| 99                                  | t <sub>PLAL</sub>  | PCSx# Active to ALE Inactive      | 23                    | 30  | ns   |
| <b>Write Cycle Timing Responses</b> |                    |                                   |                       |     |      |
| 32 <sub>a</sub>                     | T <sub>WLWH</sub>  | Write Pulse Width (PCS0#..PCS3#)  | 20 + X <sup>(1)</sup> |     | ns   |
| 32 <sub>b</sub>                     | T <sub>WLWH</sub>  | Write Pulse Width (PCS5#, PCS6#)  | 20 + X <sup>(1)</sup> |     | ns   |
| 33                                  | T <sub>WHLH</sub>  | Write Inactive to ALE High        | 10                    |     | ns   |
| 34                                  | T <sub>WHDX</sub>  | Data Hold after Write Inactive    | 15                    |     | ns   |

<sup>(1)</sup>X depends on waitstates and can be 0.. 6375ns. (see @CHIP-RTOS Doc)

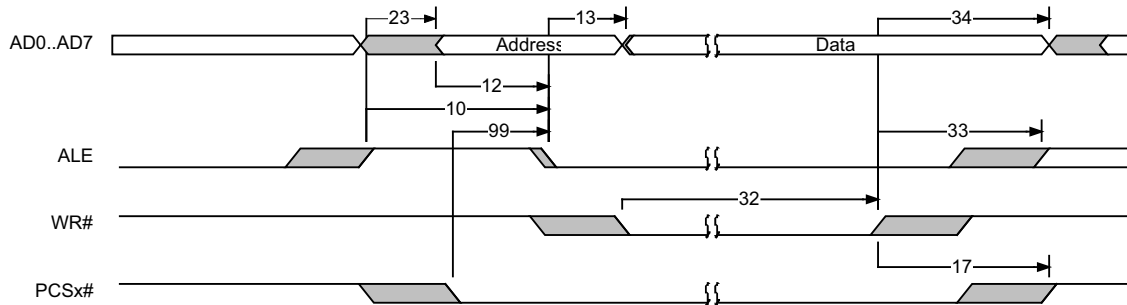

\*) the falling edge of PCS0# is 25ns delayed internally

## 10. APPLICATION EXAMPLES

The following pages contain schematics showing the IPC@CHIP® family microcontroller. It gives you suggestions, how to handle the multi-function pin 17 RESET# / NMI / LINK-LED and how to expand the IPC@CHIP.

### 10.1 NMI / Reset-in / Link-LED

#### External sample circuitry /Reset + NMI + Link LED

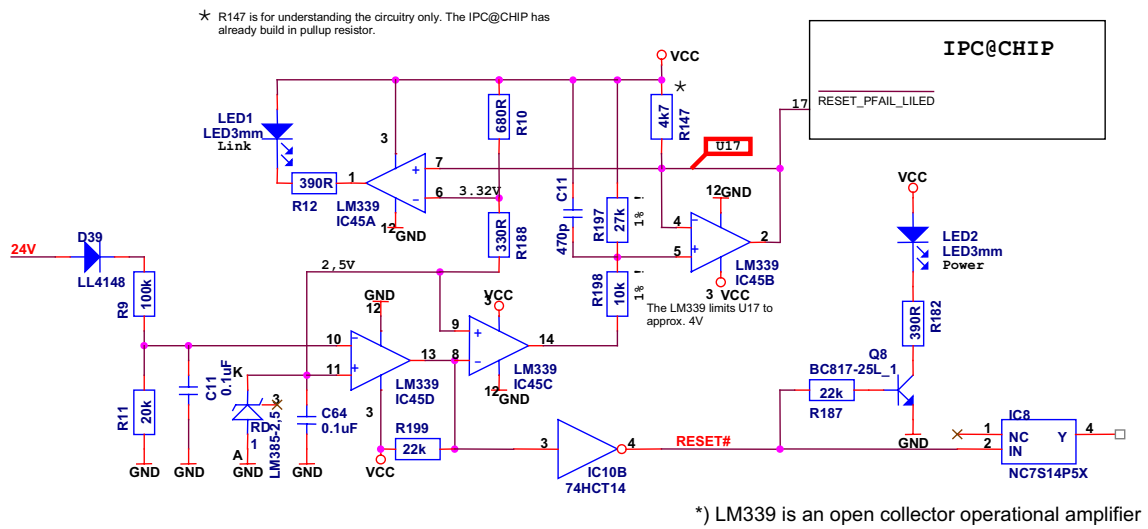

Picture 10.1: Example of using NMI, reset, traffic, (link<sup>8</sup>) at pin 17

See also DK50 schematic.

<sup>8</sup> only SC12



## 10.4 Connect 10Base-T Ethernet to the SC12

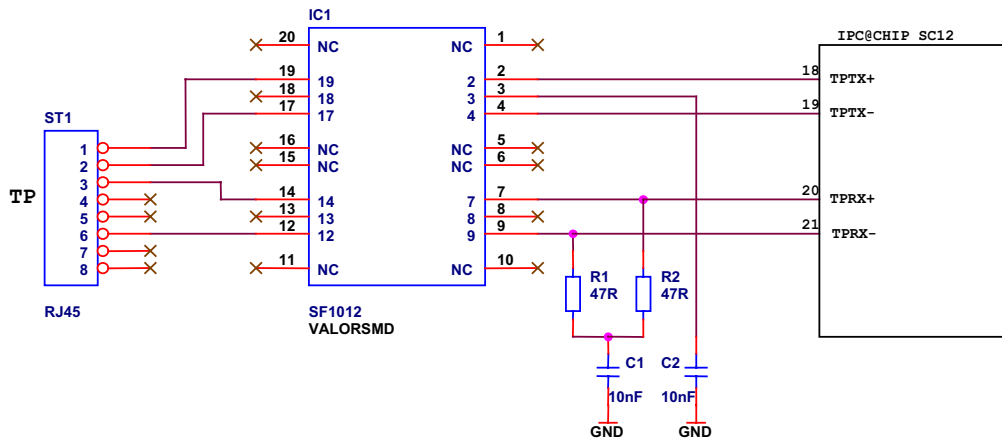

picture 10.4: Example of connecting 10Base-T to SC12 with SF1012

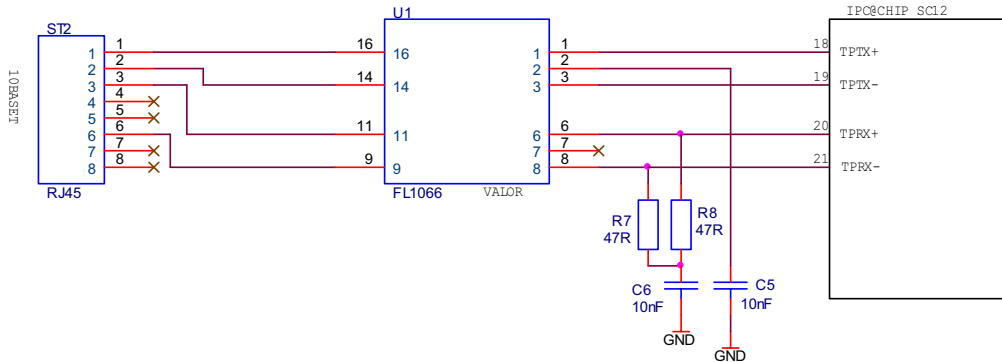

picture 10.5: Example of connecting 10Base-T to SC12 with FL1066

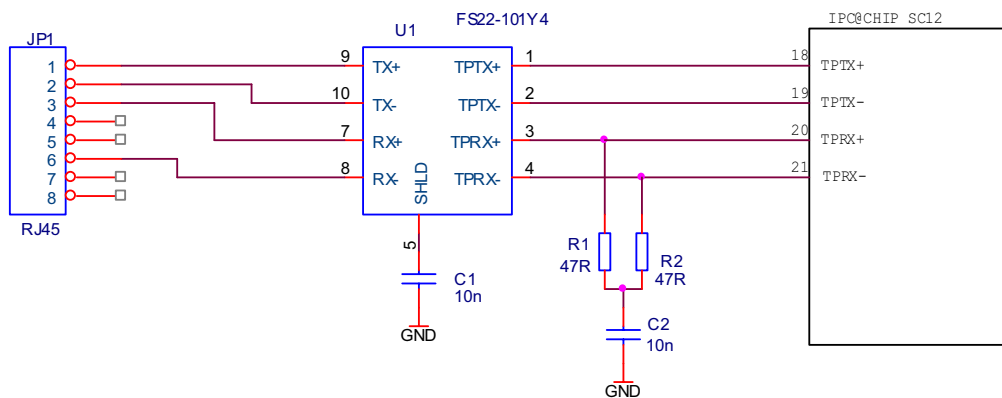

picture 10.6: Example of connecting 10Base-T to SC12 with FS22

## 10.5 Connect 10/100Base-T Ethernet to the SC13

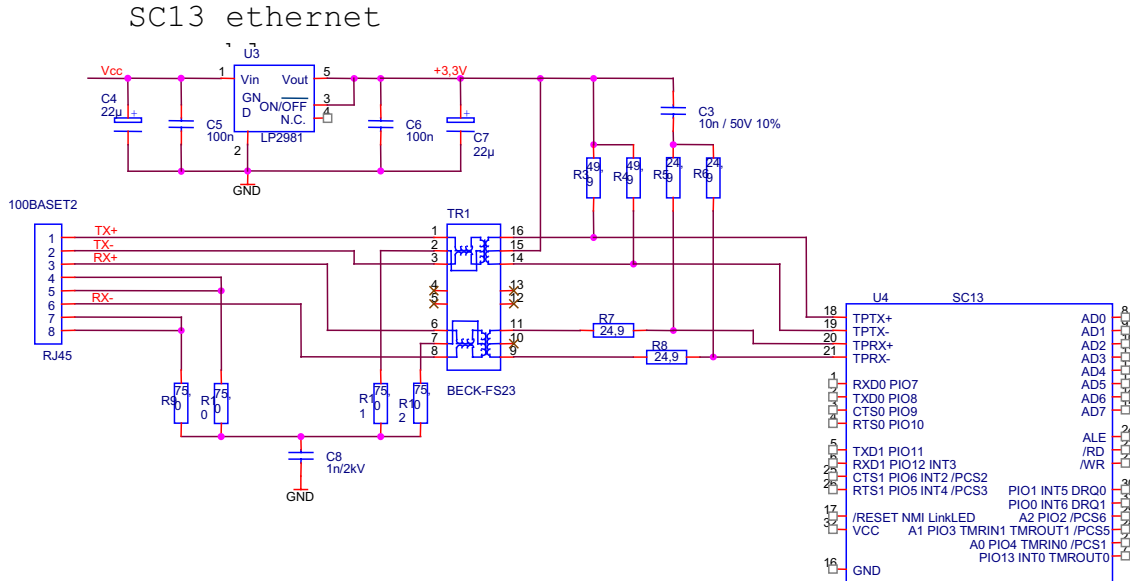

picture 10.7: Example of connecting 10/100Base-T to SC13 with FS23

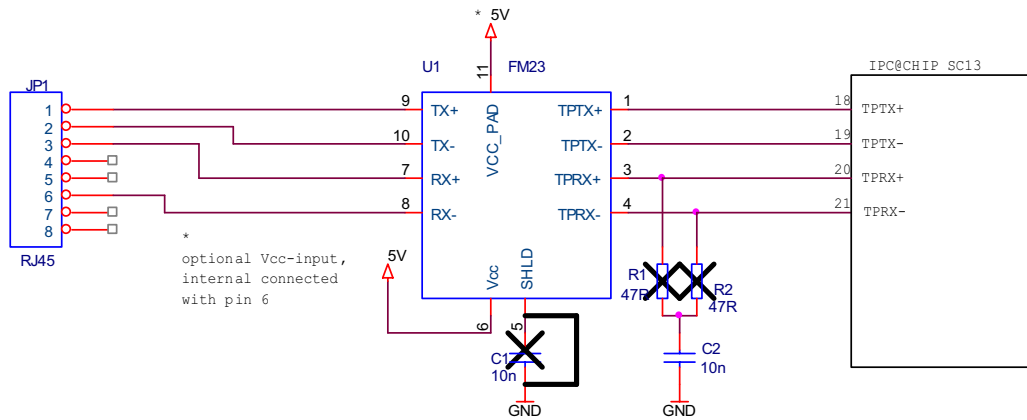

picture 10.8: Example of connecting 10/100Base-T to SC13 with FM23 (convert SC12 schematic to fit SC13, see also picture 10.6)

## 10.6 I<sup>2</sup>C-Bus Example

To use PIO pins for I<sup>2</sup>C-Bus, connect a 10kΩ resistor to each PIO pin that is defined for I<sup>2</sup>C-Bus. The definition of initializing I<sup>2</sup>C-Bus is described in the @CHIP RTOS documentation.

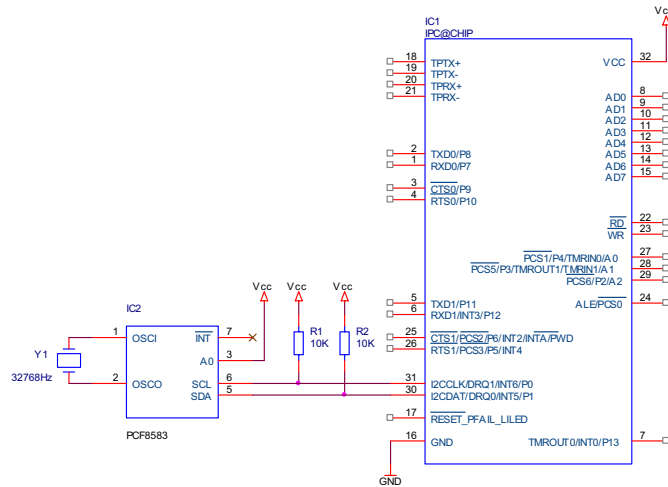

picture 10.9: Example of connecting a PCF8583 over I<sup>2</sup>C-Bus to the IPC@CHIP

## 10.7 SPI-Bus Example

To use PIO pins for SPI-Bus, see SPI serial data flash example at Beck IPC Website and @CHIP RTOS documentation.

## 10.8 Other Examples

More examples are available at the download section of the Beck-IPC Website.

## 11. CHANGE LIST

### **Whole document**

Added documentation for SC11/SC13. Some scribal errors corrected.

## 12. CONTACT

### **BECK IPC GmbH**

Garbenheimer Strasse 36 – 38  
D-35578 Wetzlar  
Germany  
Phone: +49 (0)6441-905-0  
Fax: +49 (0)6441-905-245  
Internet: [www.beck-ipc.com](http://www.beck-ipc.com)  
E-Mail: [info@beck-ipc.com](mailto:info@beck-ipc.com)

©BECK IPC GmbH All rights reserved. No part of this document may be copied or reproduced in any form or by any means without the prior written consent of BECK IPC GmbH. The information in this document is subject to change without notice. Devices sold by BECK IPC GmbH. Are covered by warranty and patent indemnification provisions appearing in BECK IPC GmbH. Terms and Conditions of Sale only. BECK IPC GmbH MAKES NO WARRANTY, EXPRESS, STATUTORY, IMPLIED OR BY DESCRIPTION, REGARDING THE INFORMATION SET FORTH HEREIN OR REGARDING THE FREEDOM OF THE DESCRIBED DEVICES FROM INTELLECTUAL PROPERTY INFRINGEMENT. BECK IPC GmbH MAKES NO WARRANTY OF MERCHANTABILITY OR FITNESS FOR ANY PURPOSE. BECK IPC GmbH Shall not be responsible for any errors that may appear in this document. BECK IPC GmbH makes no commitment to update or keep current the information contained in this document.

**Life critical applications** — These products are not designed for use in life support appliances, aeronautical applications or devices or systems where malfunction of these products can reasonably be expected to result in personal injury.

**Right to make changes** — BECK IPC GmbH reserves the right to make changes, without notice, in the products, including software, described or contained herein in order to improve design and/or performance. Beck IPC GmbH assumes no responsibility or liability for the use of any of these products.